

Metal Oxide Varistor : TVB Series



Plastic Encapsulated Type Varistor for Surge Protection

■ Features



1. RoHS compliant
2. Available for SMT flow/reflow soldering
3. Low profile and space saving
4. Large capability to withstand high surge current
5. Low inductance construction with excellent response
6. Encapsulation material according to UL94-V0
7. Operating temperature range : -40°C ~ +85°C
8. Agency recognition: UL /cUL
9. For UL 1449 3RD SPD Type 4 application

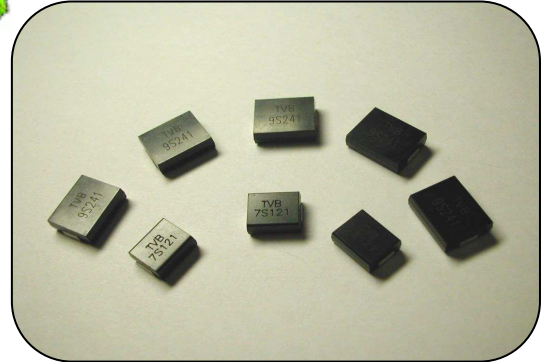

■ Recommended Applications

1. Power supply
2. Home appliance
3. Industrial equipment
4. Telecommunication or telephone system
5. Automobile

■ Part Number Code

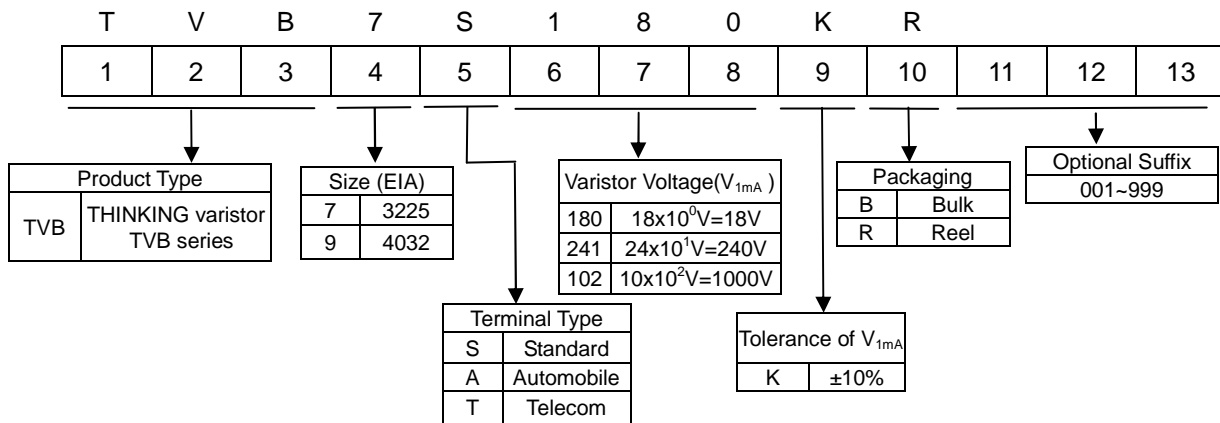

Metal Oxide Varistor : TVB Series



Plastic Encapsulated Type Varistor for Surge Protection

Structures and Dimensions

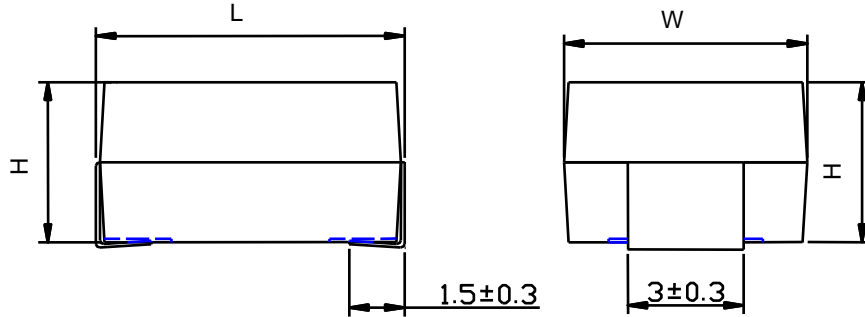

(Unit: mm)

Size (EIA)	Varistor Voltage Range	L	W	H
3225	$V_{1mA}=180 \sim 271$	8.0+/- 0.3	6.3+/- 0.3	3.2+/- 0.3
	$V_{1mA}=361 \sim 561$			4.5+/- 0.3
4032	$V_{1mA}=180 \sim 271$	10.2+/- 0.3	8.0+/- 0.3	3.2+/- 0.3
	$V_{1mA}=361 \sim 751$			4.5+/- 0.3

Soldering Pads

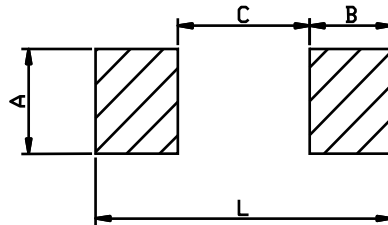

(Unit: mm)

Item		A	B	C	L
Size	3225	3.5	2.8	4.5	10.1
(EIA)	4032	3.5	2.8	6.5	12.1

Metal Oxide Varistor : TVB Series



Plastic Encapsulated Type Varistor for Surge Protection

■ Electrical Characteristics

Part No.	Varistor Voltage (@ 1mA DC)	Max. Operating Voltage		Max. Clamping voltage (8/20μs)		Max. Surge Current (8/20μs)	Max. Energy (10/1000μS)	Rated Power	Reference Capacitance @1KHz	Safety Approvals	
		V _{1mA} (V)	V _{AC(rms)} (V)	V _{DC} (V)	V _P (V)					I _P (A)	W _{max} (J)
TVB7S180	18	11	14	36	1.0	150	0.6	0.01	1750	√	√
TVB7S220	22	14	18	43	1.0	150	0.7	0.01	1450	√	√
TVB7S270	27	17	22	53	1.0	150	0.9	0.01	1200	√	√
TVB7S330	33	20	26	65	1.0	150	1.1	0.01	980	√	√
TVB7S390	39	25	31	77	1.0	150	1.2	0.01	850	√	√
TVB7S470	47	30	38	93	1.0	150	1.5	0.01	720	√	√
TVB7S560	56	35	45	110	1.0	150	1.8	0.01	620	√	√
TVB7S680	68	40	56	135	1.0	150	2.2	0.01	520	√	√
TVB7S820	82	50	65	135	5.0	400	2.5	0.1	300	√	√
TVB7S101	100	60	85	165	5.0	400	3.0	0.1	250	√	√
TVB7S121	120	75	100	200	5.0	400	4.0	0.1	210	√	√
TVB7S151	150	95	125	250	5.0	400	6.0	0.1	135	√	√
TVB7S181	180	115	150	300	5.0	400	6.5	0.1	110	√	√
TVB7S201	205	130	170	340	5.0	400	7.0	0.1	100	√	√
TVB7S221	220	140	180	360	5.0	400	7.5	0.1	95	√	√
TVB7S241	240	150	200	395	5.0	400	9.0	0.1	90	√	√
TVB7S271	270	175	225	455	5.0	400	9.5	0.1	75	√	√
TVB7S361	360	230	300	595	5.0	400	10.0	0.1	60	√	√
TVB7S391	390	250	320	650	5.0	400	11.0	0.1	55	√	√
TVB7S431	430	275	350	710	5.0	400	13.0	0.1	50	√	√
TVB7S471	470	300	385	775	5.0	400	15.0	0.1	45	√	√
TVB7S511	510	320	410	845	5	400	16.5	0.1	40	√	√
TVB7S561	560	350	450	930	5	400	18.0	0.1	35	√	√

Metal Oxide Varistor : TVB Series



Plastic Encapsulated Type Varistor for Surge Protection

Part No.	Varistor Voltage (@ 1mA DC)	Max. Operating Voltage		Max. Clamping Voltage (8/20µs)		Max. Surge Current (8/20µs)	Max. Energy (10/1000µS)	Rated Power	Reference Capacitance @1KHz	Safety Approvals	
		V _{1mA} (V)	V _{AC(rms)} (V)	V _{DC} (V)	V _P (V)					I _P (A)	UL
TVB9S180	18	11	14	36	2.5	300	1.1	0.02	2750	√	√
TVB9S220	22	14	18	43	2.5	300	1.3	0.02	2300	√	√
TVB9S270	27	17	22	53	2.5	300	1.6	0.02	1900	√	√
TVB9S330	33	20	26	65	2.5	300	2.0	0.02	1600	√	√
TVB9S390	39	25	31	77	2.5	300	2.4	0.02	1400	√	√
TVB9S470	47	30	38	93	2.5	300	2.8	0.02	1200	√	√
TVB9S560	56	35	45	110	2.5	300	3.4	0.02	1050	√	√
TVB9S680	68	40	56	135	2.5	300	4.1	0.02	900	√	√
TVB9S820	82	50	65	135	10	1200	6.5	0.25	530	√	√
TVB9S101	100	60	85	165	10	1200	7.0	0.25	480	√	√
TVB9S121	120	75	100	200	10	1200	9.0	0.25	430	√	√
TVB9S151	150	95	125	250	10	1200	11.0	0.25	260	√	√
TVB9S181	180	115	150	300	10	1200	13.0	0.25	220	√	√
TVB9S201	205	130	170	340	10	1200	15.0	0.25	200	√	√
TVB9S221	220	140	180	360	10	1200	18.0	0.25	180	√	√
TVB9S241	240	150	200	395	10	1200	18.5	0.25	170	√	√
TVB9S271	270	175	225	455	10	1200	21.0	0.25	150	√	√
TVB9S361	360	230	300	595	10	1200	23.0	0.25	115	√	√
TVB9S391	390	250	320	650	10	1200	25.0	0.25	105	√	√
TVB9S431	430	275	350	710	10	1200	29.0	0.25	95	√	√
TVB9S471	470	300	385	775	10	1200	30.0	0.25	90	√	√
TVB9S511	510	320	410	845	10	1200	33.0	0.25	85	√	√
TVB9S561	560	350	450	930	10	1200	33.0	0.25	80	√	√
TVB9S751	750	460	615	1235	10	1200	50.5	0.25	55	√	√

Metal Oxide Varistor : TVB Series



Plastic Encapsulated Type Varistor for Surge Protection

■ Power Derating Curve

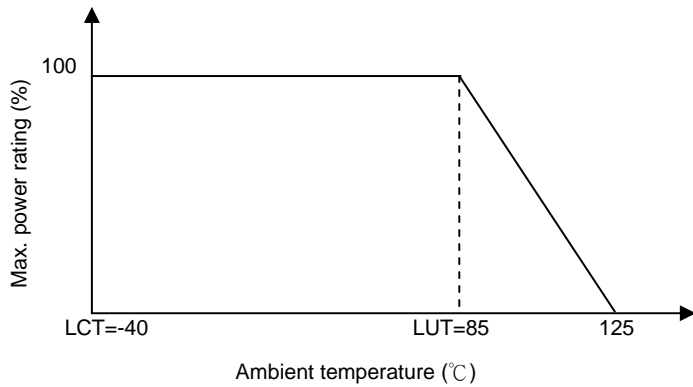

■ Surge Current Standard Waveform

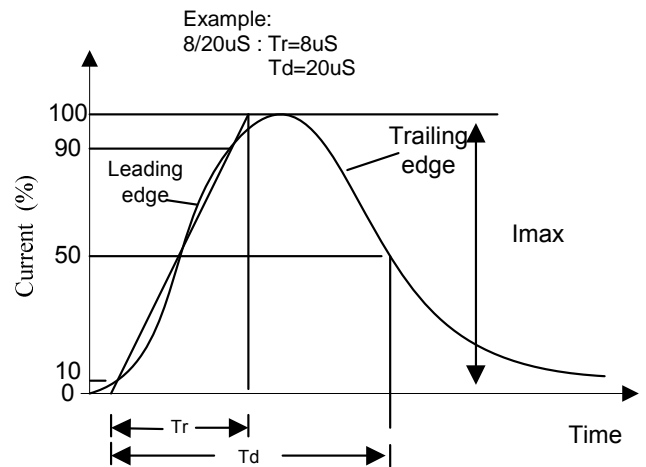

■ Max. Surge Current Derating Curves

TVB 7S 180 to TVB 7S 680

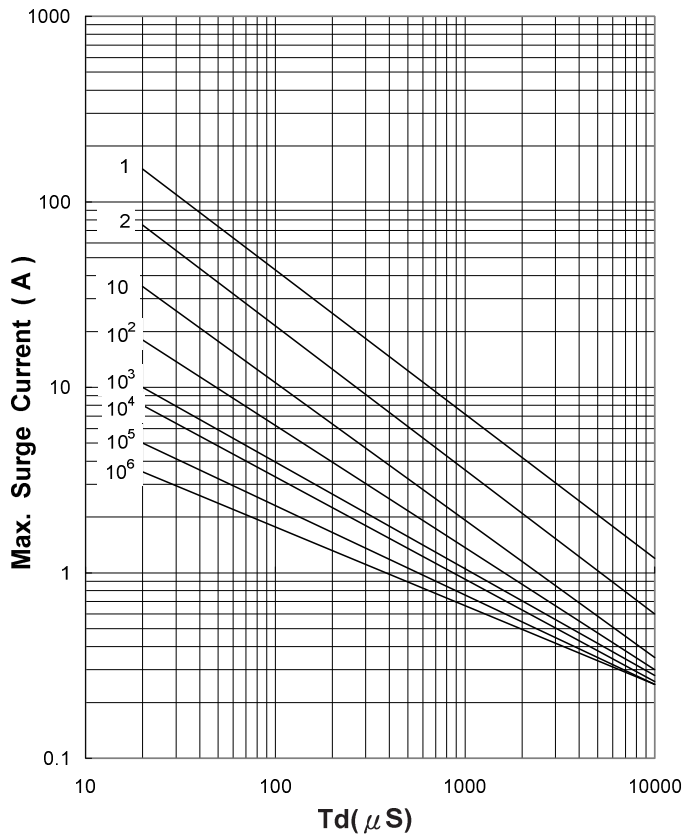

TVB 7S 820 to TVB 7S 561

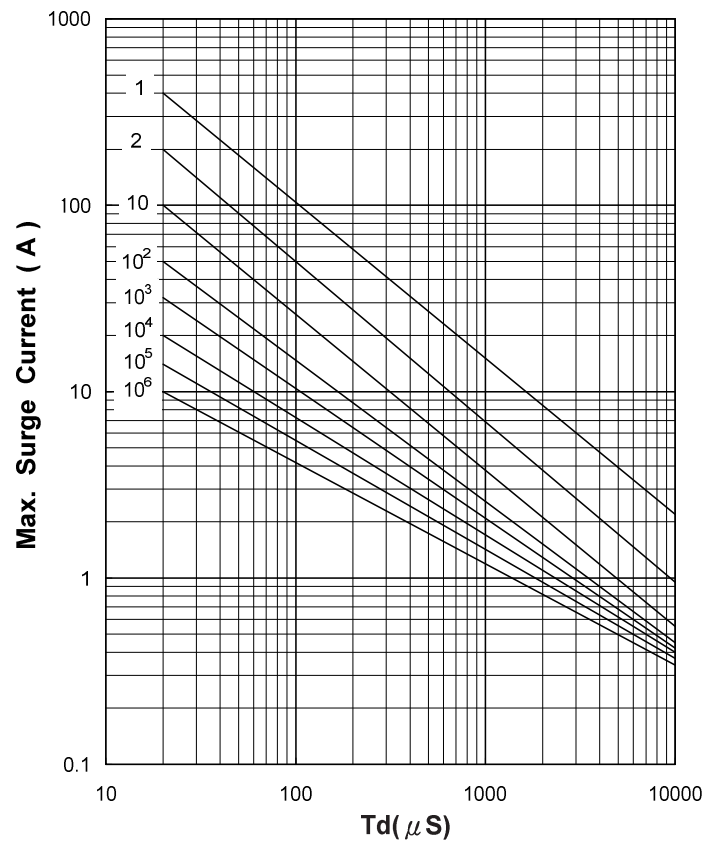

Metal Oxide Varistor : TVB Series



Plastic Encapsulated Type Varistor for Surge Protection

■ Max. Surge Current Derating Curves

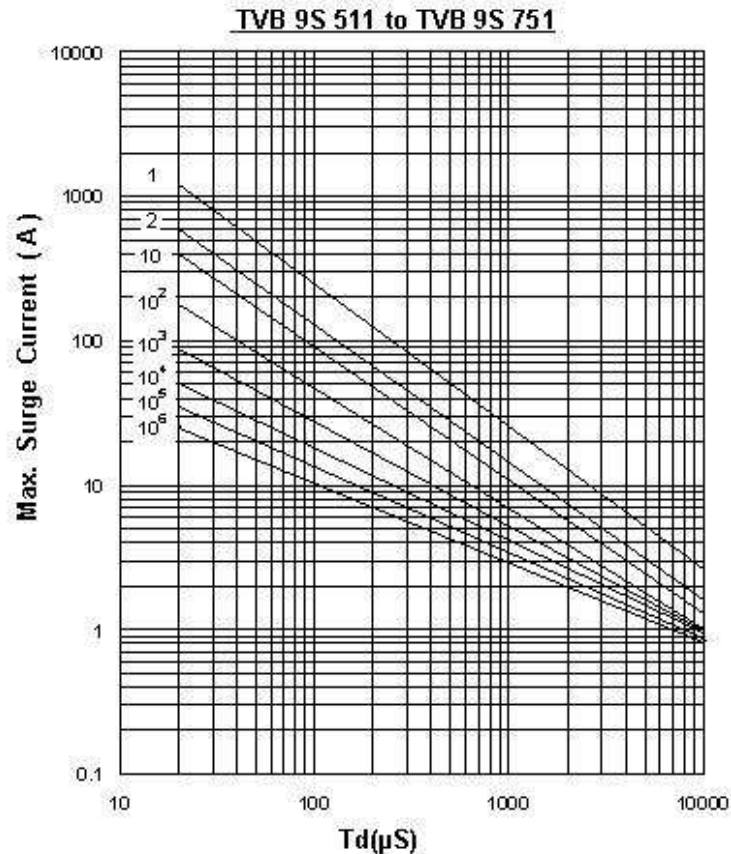
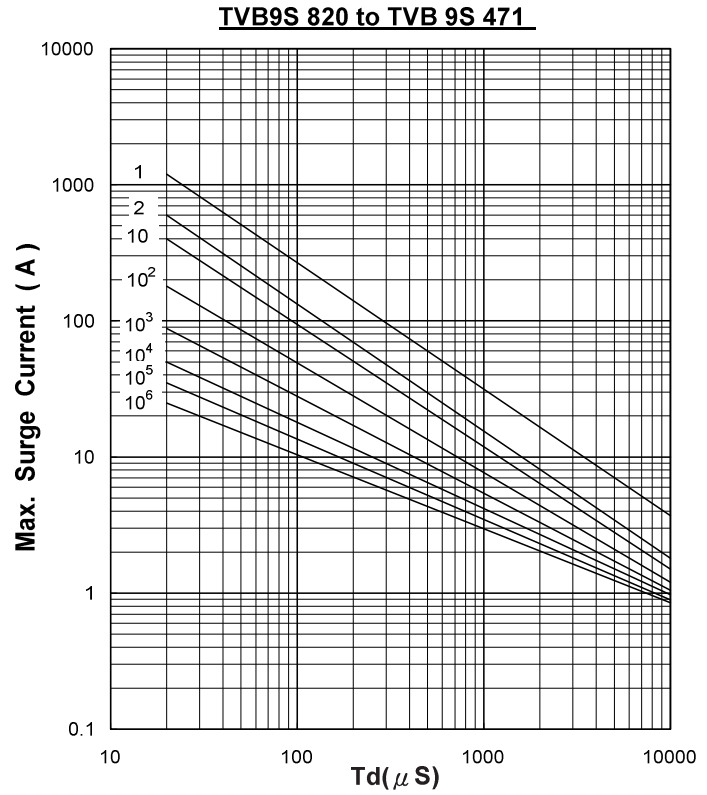
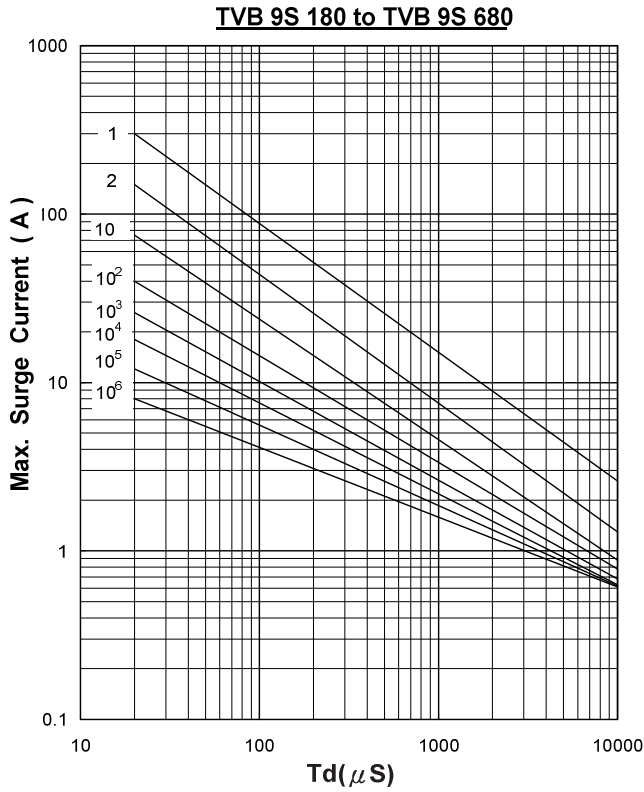

Metal Oxide Varistor : TVB Series



Plastic Encapsulated Type Varistor for Surge Protection

■ Max. Leakage Current and Max. Clamping Voltage Curves

Max. Leakage Current and Max. Clamping Voltage Curves (TVB7S 180 to TVB7S 680)

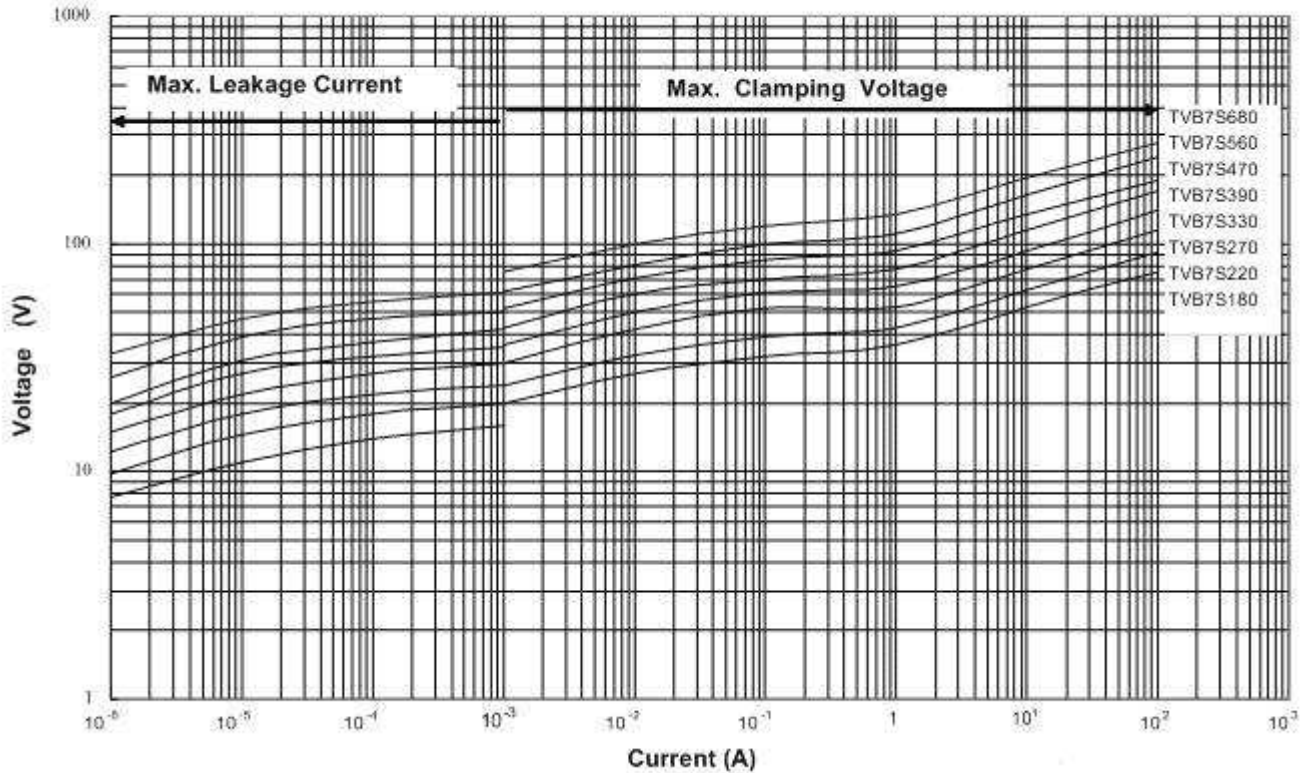

Max. Leakage Current and Max. Clamping Voltage Curves (TVB7S820 to TVB 7S561)

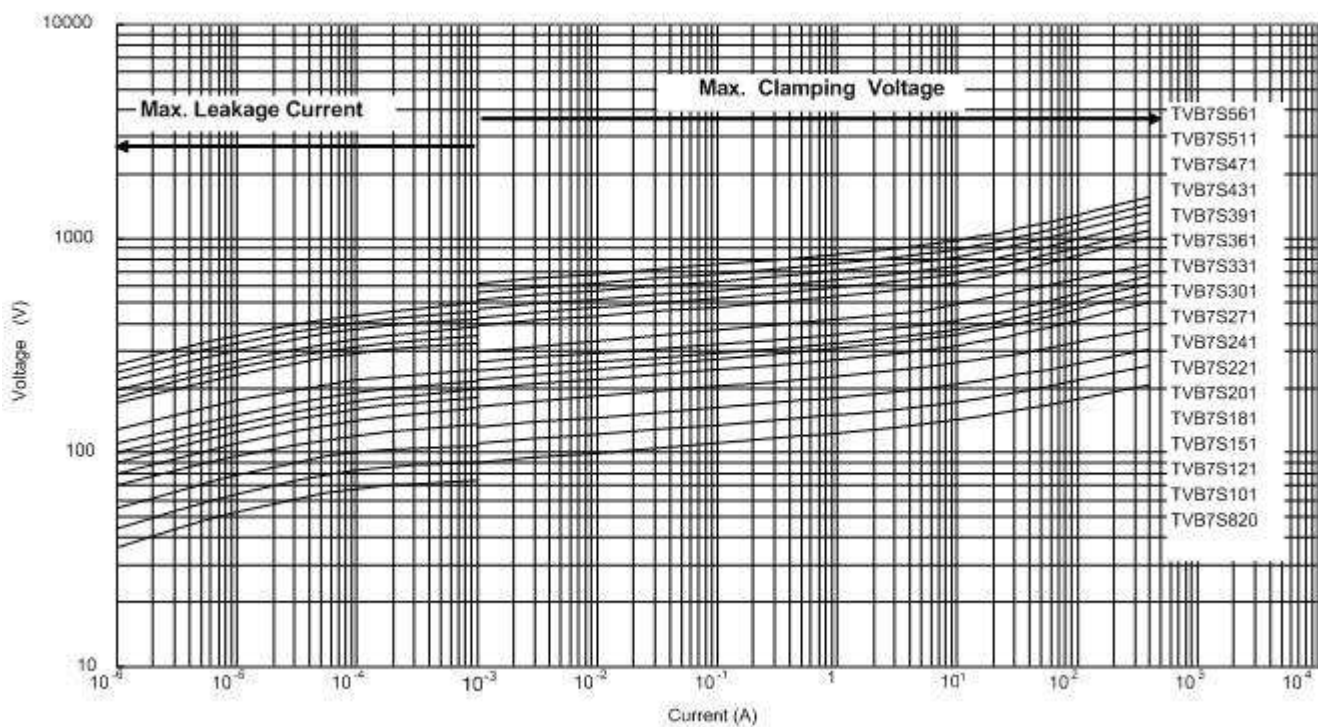

Metal Oxide Varistor : TVB Series

Plastic Encapsulated Type Varistor for Surge Protection



Max. Leakage Current and Max. Clamping Voltage Curves (TVB9S 180 to TVB 9S 680)

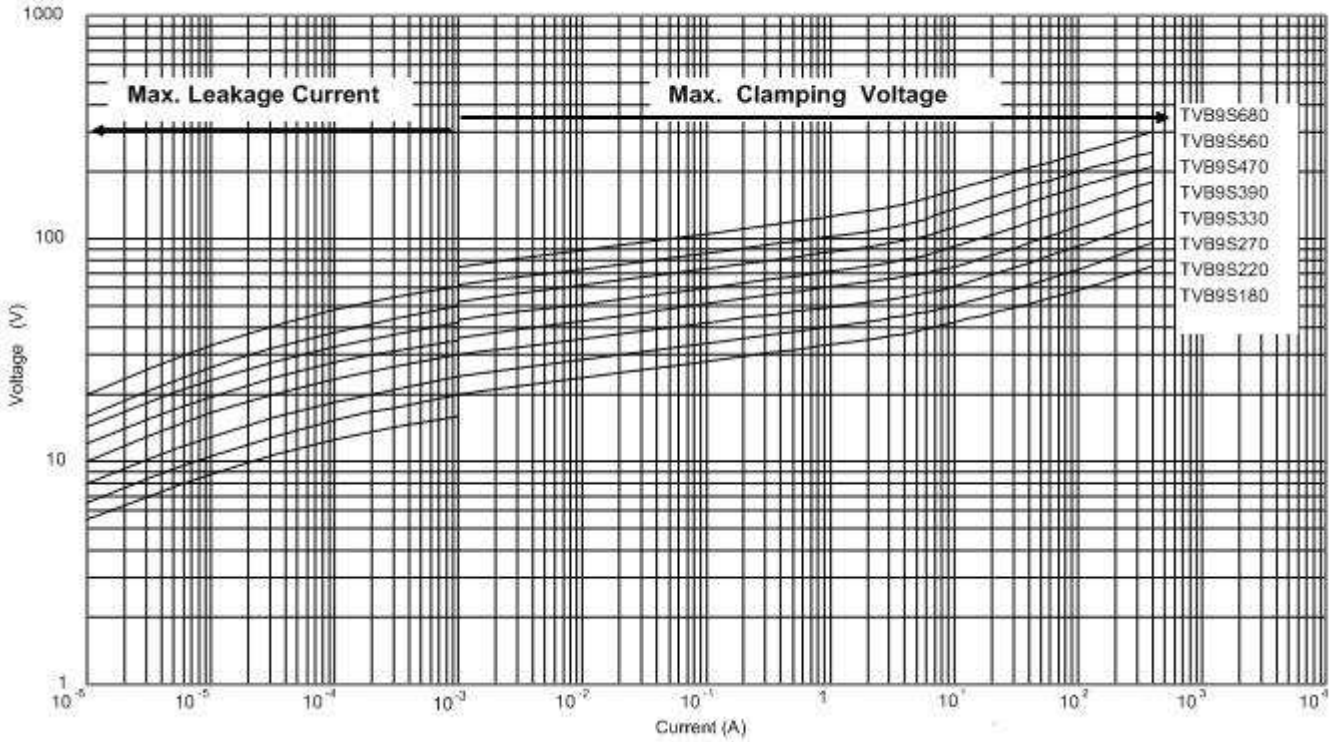

Max. Leakage Current and Max. Clamping Voltage Curves (TVB9S 820 to TVB9S 471)

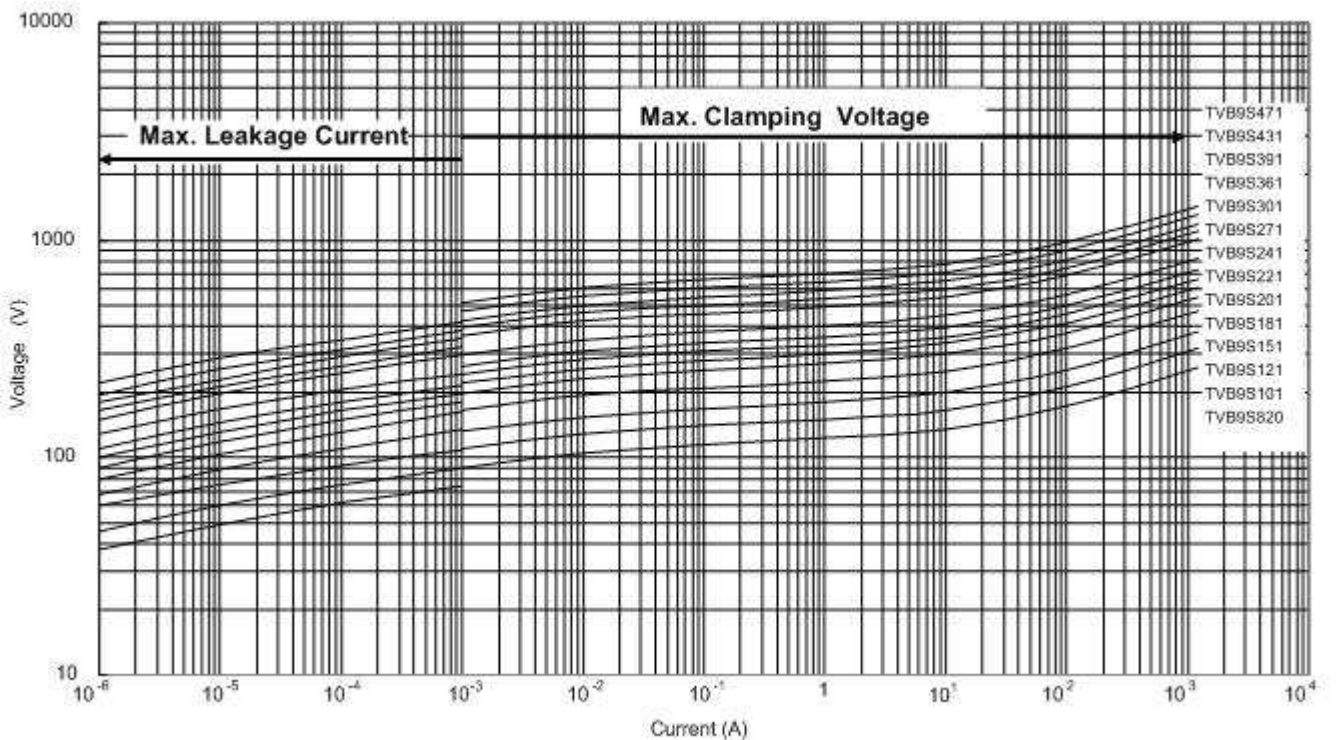

Metal Oxide Varistor : TVB Series

Plastic Encapsulated Type Varistor for Surge Protection



Max. Leakage Current and Max. Clamping Voltage Curves (TVB 9S 511 to TVB 9S 751)

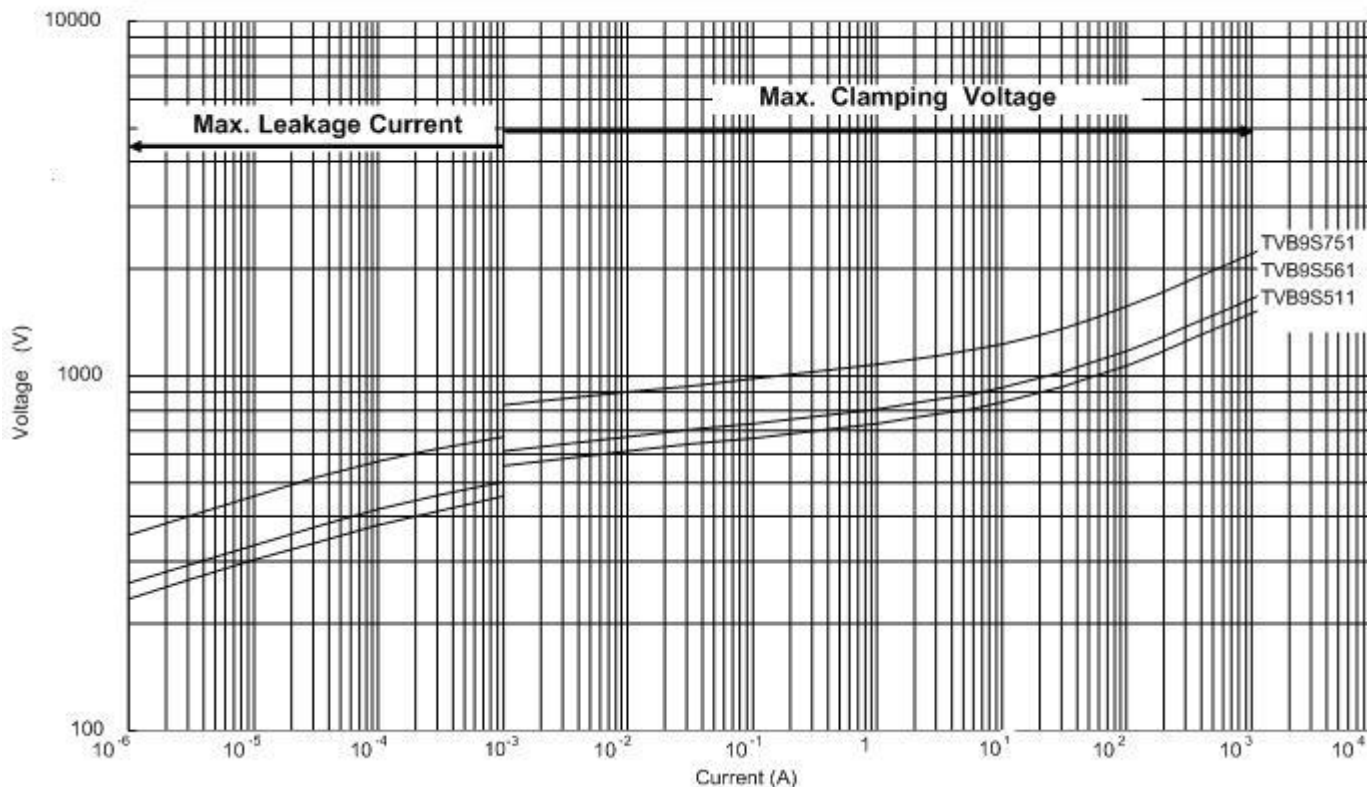

Metal Oxide Varistor : TVB Series



Plastic Encapsulated Type Varistor for Surge Protection

■ Soldering Recommendation

● Wave Soldering Profile

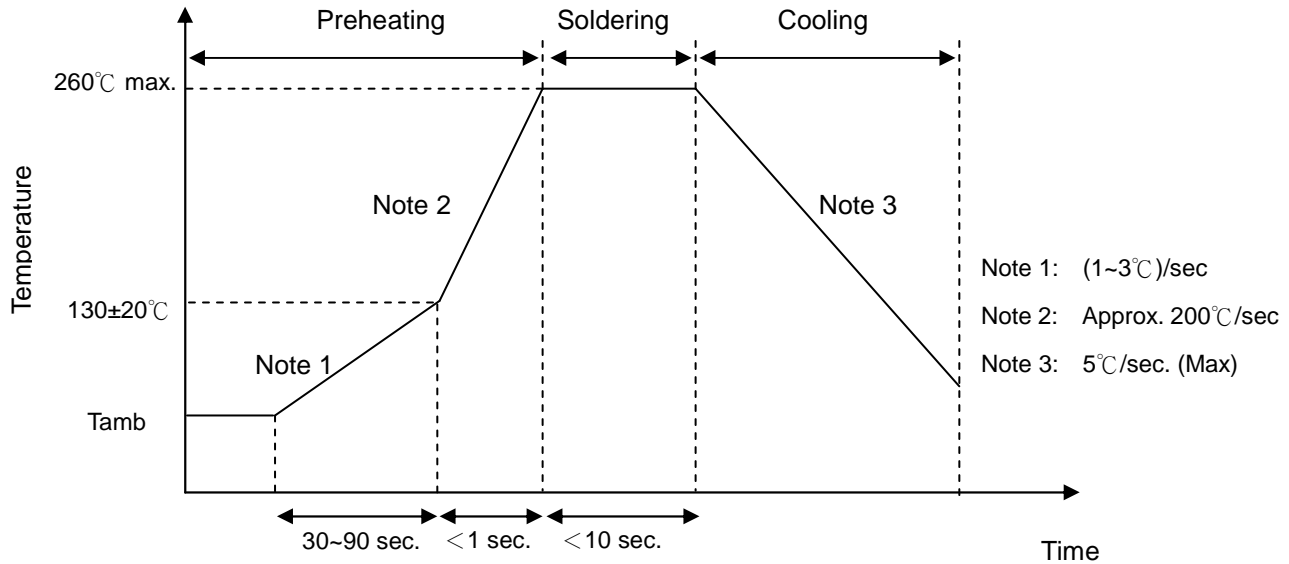

● IR-reflow Soldering Profile

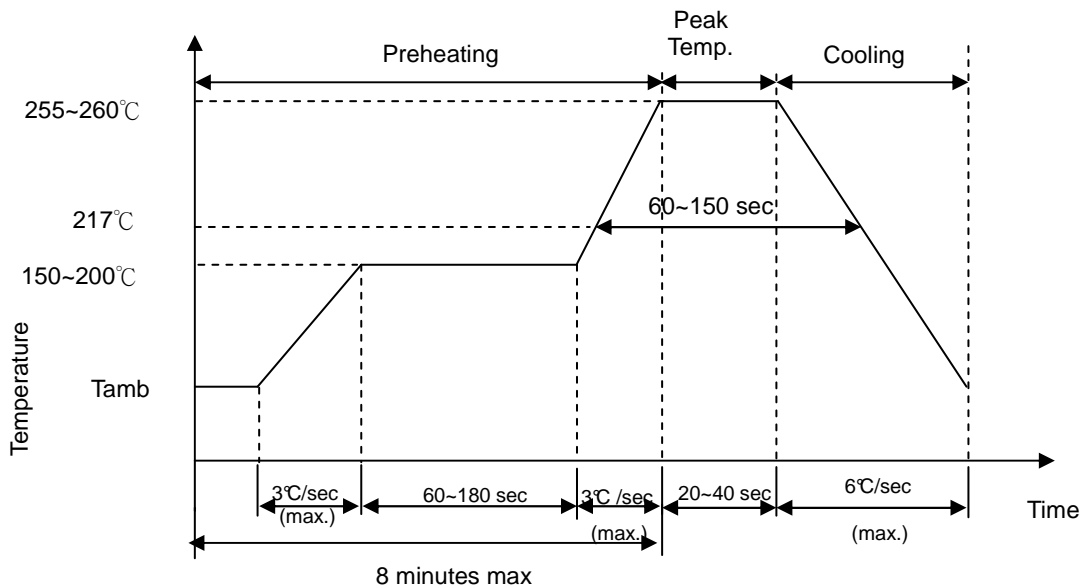

● Recommended Reworking Conditions with Soldering Iron

Item	Conditions
Temperature of Soldering Iron-tip	350°C (max.)
Soldering Time	3 sec (max.)
Diameter of Soldering Iron-tip	Φ3 mm (max.)

Metal Oxide Varistor : TVB Series



Plastic Encapsulated Type Varistor for Surge Protection

■ Reliability

Item	Standard	Test conditions / Methods	Specifications															
Vibration	IEC 1051-1	Frequency range:10~55Hz Amplitude:0.75mm or 98m/S ² Direction:3 mutually perpendicular directions,2hrs each.	$ \Delta V/V_{1mA} \leq 5\%$ No visible damage															
Solderability	IEC 60068-2-20	245±3°C , 3±0.3 sec	At least 95% of terminal electrode is covered by new solder															
Resistance to Soldering Heat	IEC 60068-2-20	260±3°C , 10±1 sec,	$ \Delta V/V_{1mA} \leq 5\%$ No visible damage															
High Temperature Storage	IEC 60068-2-2	125±5°C x 1000 ±24 hrs	$ \Delta V/V_{1mA} \leq 5\%$															
Damp Heat, Steady State	IEC 60068-2-3	a. 40±2°C, 90 ~ 95 % RH, 1344 hrs. b. 40±2°C, 90 ~ 95 % RH, at 10%Vdc, 1344 hrs	No visible damage $ \Delta V/V_{1mA} \leq 5\%$ Insulation Resistance ≥ 100MΩ															
Rapid Change of Temperature	IEC 60068-2-14	The conditions shown below shall be repeated 5 cycles <table border="1" style="margin-left: auto; margin-right: auto;"> <thead> <tr> <th>Step</th> <th>Temperature (°C)</th> <th>Period (minutes)</th> </tr> </thead> <tbody> <tr> <td>1</td> <td>-40±3</td> <td>30±3</td> </tr> <tr> <td>2</td> <td>Room temperature</td> <td>5±3</td> </tr> <tr> <td>3</td> <td>85±2</td> <td>30±3</td> </tr> <tr> <td>4</td> <td>Room temperature</td> <td>5±3</td> </tr> </tbody> </table>	Step	Temperature (°C)	Period (minutes)	1	-40±3	30±3	2	Room temperature	5±3	3	85±2	30±3	4	Room temperature	5±3	$ \Delta V/V_{1mA} \leq 5\%$ No visible damage
Step	Temperature (°C)	Period (minutes)																
1	-40±3	30±3																
2	Room temperature	5±3																
3	85±2	30±3																
4	Room temperature	5±3																
Endurance at Upper Category Temperature	IEC61051-4.20	85 ± 2 °C, 1000 ± 24 hrs, at VDC or Vrms (Max. Operating Voltage)	$ \Delta V/V_{1mA} \leq 10\%$															
8/20μs Surge Life	CECC42000	10,000 pulses (8/20μS), unipolar, interval 10 secs, amplitude corr. to max. Surge current derating curves for 20μS	$ \Delta V/V_{1mA} \leq 10\%$ No visible damage															
Varistor VoltageTemp. Coefficient	Specification Standard	$\frac{V_{1mA} \text{ at } 85^{\circ}\text{C} - V_{1mA} \text{ at } 25^{\circ}\text{C}}{V_{1mA} \text{ at } 25^{\circ}\text{C}} \times \frac{1}{60} \times 100 (\% / ^{\circ}\text{C})$ $\frac{V_{1mA} \text{ at } -40^{\circ}\text{C} - V_{1mA} \text{ at } 25^{\circ}\text{C}}{V_{1mA} \text{ at } 25^{\circ}\text{C}} \times \frac{1}{65} \times 100 (\% / ^{\circ}\text{C})$	-0.05 ≤ T _C ≤ 0.05 (% / °C)															
Voltage Proof	IEC61051-4.8	Metal balls method, 2500 V _{ac} 1 min	No visible damage															

Metal Oxide Varistor : TVB Series



Plastic Encapsulated Type Varistor for Surge Protection

■ Packaging

● Taping Specification

16mm plastic embossed

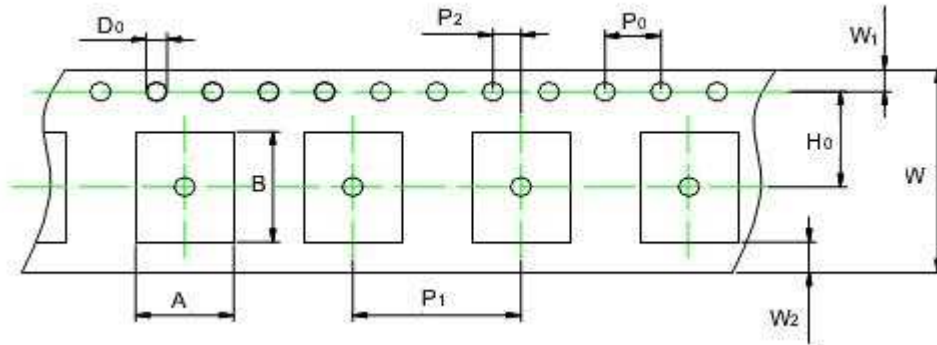

Item	A*B	P_0	P_1	P_2	H_0	W	W_1	W_2	D_0	
Size	3225	7.0*8.7	4.0	12.0	2.0	7.5	16	1.75	0.75	1.5
	4032	8.6*10.6								
Tolerance	+/- 0.2	+/- 0.1	+/- 0.1	+/- 0.05	+/- 0.05	+/- 0.3	+/- 0.1	Min.	+0.1 -0	

● Quantity

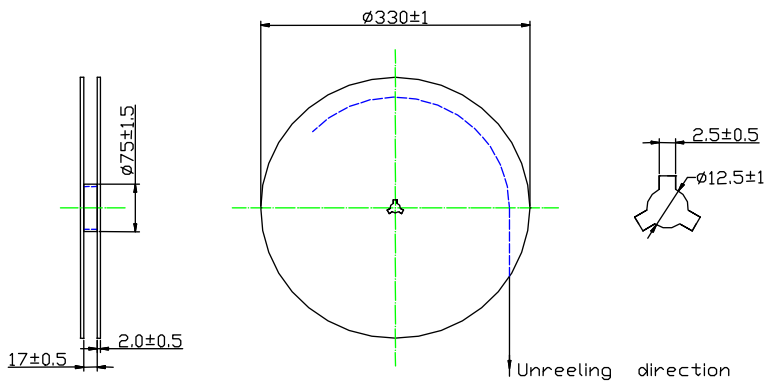

Size	Quantity (pcs/reel)
3225	1000
4032	1000

■ Storage Conditions of Products

● Storage Conditions :

1. Storage Temperature : $-10^{\circ}\text{C} \sim +40^{\circ}\text{C}$
2. Relative Humidity : $\leq 75\% \text{RH}$
3. Keep away from corrosive atmosphere and sunlight.

● Period of storage : 1 year