

MECHANICAL DIMENSIONS

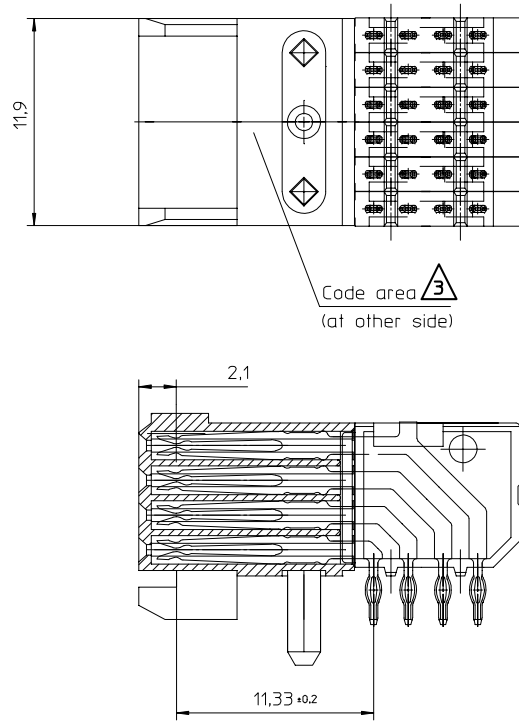

NOTES

- 1 TO DEFINE EXACT PART NUMBER SEE PLATING TABLE UNDERNEATH
- 2 MATERIAL OF CONTACT : PHOSPHORBRONZE  
MATERIAL OF HOUSING : LCP ZENITE 6130  
NATURAL WHITE
- 3 CONNECTOR MARKED WITH PART NUMBER AND DATE CODE

RECOMMEND PCB-HOLE LAYOUT

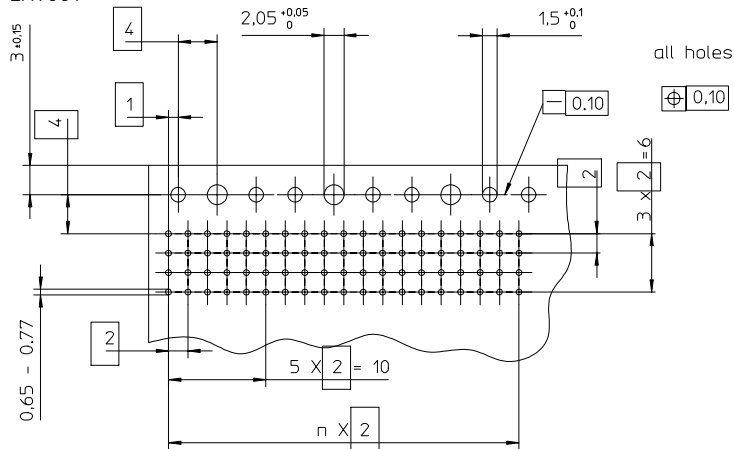

PLATING TABLE

	um Au	um Au	um SnPb	um Ni
HM1-P008-FA4-P1	1,25		0,8	1,3
HM1-P008-FA4-P2		0,8	0,8	1,3
	Performance			
	Level 1	Level 2	PIN	Under coating
Part number	Contact area		area	

No.	Name of part or name of assembly drawing	Drawing and part number	Standard	Format, dimensions, type	Qty.
				Material	
				Symbol of part	
Product/Draw.no.	Interface/Draw.no.	Mass kg Calcul. Weigh	General tolerance	Scale	Desig. Check. Appd.
				08.11.01	

PERLOS

STANDARD *Permet 2.0*

Replaces Replaced