

BATTERY DRIVE, FTP-608 Series

2" HIGH SPEED THERMAL PRINTER

FTP-628 MCL101/103, Easy Loading Method

■ OVERVIEW

The easy loading FTP-608 MCL Series is ultra compact high speed, battery driven thermal printer, printing on 2-inch wide paper (58mm) where platens are removable. Our original platen removal mechanism improved paper loading and maintenance.

The FTP-608 MCL series can be used for a variety of applications, such as portable terminals, POS, ticket issuing terminals, label printers, banking terminals, and measurement and medical equipment.

■ HIGHLIGHTS

- **Easy loading type**
Our original platen removal mechanism improved paper loading and maintenance.
- **Ultra compact**
Height 15.5 mm, width 70.3 mm, depth 33.0 mm for the 2 inch model.
- **High speed printing**
It can print at 60 mm/s (480 dotlines/s) maximum by using Fujitsu's unique head drive control.
- **High resolution printing**
8 dots/mm of resolution printing is possible.



FTP-628MCL101/103

■ PART NUMBERS

Item		Part Number
Printer mechanism		FTP-628MCL101 (2-inch wide paper: 58mm) without platen open detect switch FTP-628MCL103 (2-inch wide paper: 58mm) with platen open detect switch
LSI for driving		FTP-628CU301 (ANK only)
Interface Board	Parallel	FTP-628DCL300 (Centronics)
	Serial	FTP-628DSL305 (RS 232C)
Interface Cables	Parallel	FTP-628Y202
	Serial	FTP-628Y302
Power cable	Head, motor, logic	FTP-628Y402

■ SPECIFICATIONS

Item	Specifications
Part number	FTP-628MCL101/103
Printing method	Thermal-line dot method
Dot structure	384 dots/line
Dot pitch (Horizontal)	0.125 mm (8 dots/mm)—Dot density
Dot pitch (Vertical)	0.125 mm (8 dots/mm)—Line feed pitch
Effective printing area	48 mm
Number of columns	ANK 32 columns/line (maximum 12x 24 dot font)
Paper width	58 mm ^{±0.5}
Paper thickness	60 to 100 μ m (some paper in this range may not be used because of paper characteristics)
Printing Speed	Maximum 60mm/sec. (480 dot line/sec.) at 8.5V
Character types	Alphanumeric, katakana: 159 types International and special characters: 195 types JIS Kanji level 1, level 2, non-Kanji (supported only when Kanji CG is mounted): about 6800 types
Character, dimensions (H×W), number of columns ANK, Kanji	12 × 24 dots, (1.5 × 3.0mm), 32 columns: ANK 24 × 24 dots, (3.0 × 3.0mm), 16 columns: 8 × 16 dots, (1.0 × 2.0 mm), 48 columns: ANK 16 × 16 dots, (2.0 × 2.0 mm), 24 columns: ANK, Kanji

■ SPECIFICATIONS

Item		Specification	
		FTP-628MCL101/103	
Interface		Conforms to RS232C / Centronics	
Operating Voltage	For print head	4.2 VDC to 8.5 V, average current 0.87A (0.93), peak value Printing ratio: 12.5%, printing speed 50mm/sec. at 7.2 V	
	For motor	4.2 VDC to 8.5 V, 1 A maximum	
	For logic	5 VDC \pm 5%, 0.1 A maximum	
Dimensions	Printer mechanism	70.3 x 33.0 x 15.5 mm (WxDxH)	
	Interface board	69.3 x 52 x 15mm (WxDxH)	
Weight	Printer mechanism	Approximately 42g	
	Interface board	Approximately 20g	
Head life		Pulse resistance: 100 million pulses/dot (under our standard conditions). Abrasion resistance: paper traveling distance 50km (print ratio: 25% or less)	
Operating environment	Operating temperature*	0° C to +50° C	
	Operating humidity	20 to 85% RH (no condensation)	
	Storage temperature	-20° C to +60° C (paper not included)	
	Storage humidity	5 to 95% RH (no condensation)	
Detection function	Head temperature detection	Detected by thermistor	
	Paper out/mark detection	Detected by photo-interrupter	
Recommended thermal sensitive paper		High sensitive paper:	TF50KS-E4 (Nippon Paper)
		Standard paper:	TK50KS-E (Nippon Paper) PD150R (Oji Paper) FTP-020P0701 (58mm)
		Medium life storage paper:	TK60KS-F1 (Nippon Paper) FTP-020P0102 (58mm) PD170R (Oji Paper) AFP220VBB-1 (Mitsubishi Paper)
		Long life storage paper:	PD160R-N (Oji Paper) AFP-235 (Mitsubishi Paper) TP50KJ-R (Nippon Paper) HA112AA (Nippon Paper)

*+5°C to +40°C printing density assurance range (-25 to 70°C capability)

FTP-628MCL101/103

FUNCTION

Item	Item
1. Test print function	8. Mark detection function
2. Paper out detection	9. MCU operation abnormality detection
3. Paper near end detection	10. Power ON/OFF sequence protection
4. Thermal head temperature abnormality detection	11. Motor over-current protection
5. Blow-out fuse detection	12. Hardware timer
6. Head voltage abnormality detection	
7. Motor power saving function	

DIMENSIONS

1. Printer mechanism: 2- inch

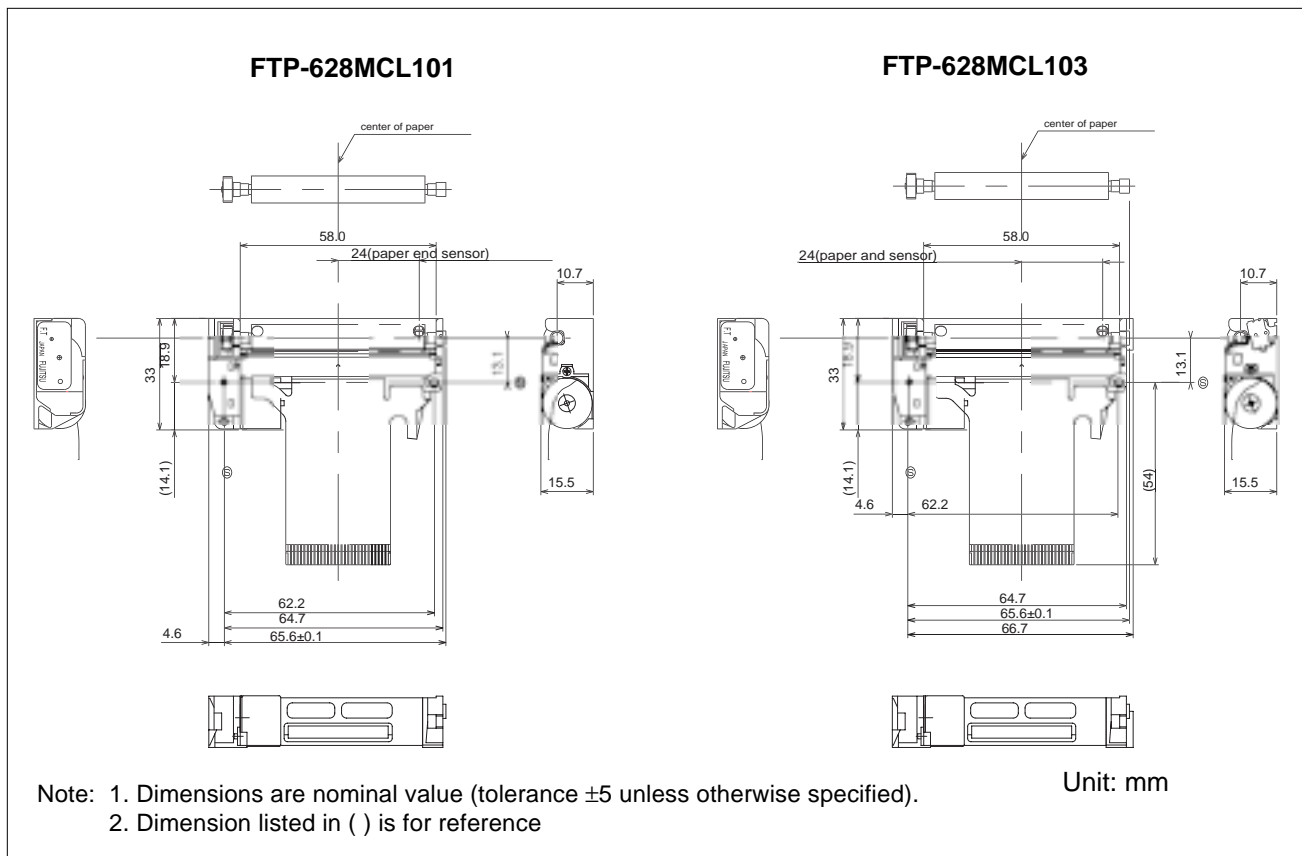

■ DIMENSIONS

2. Interface board

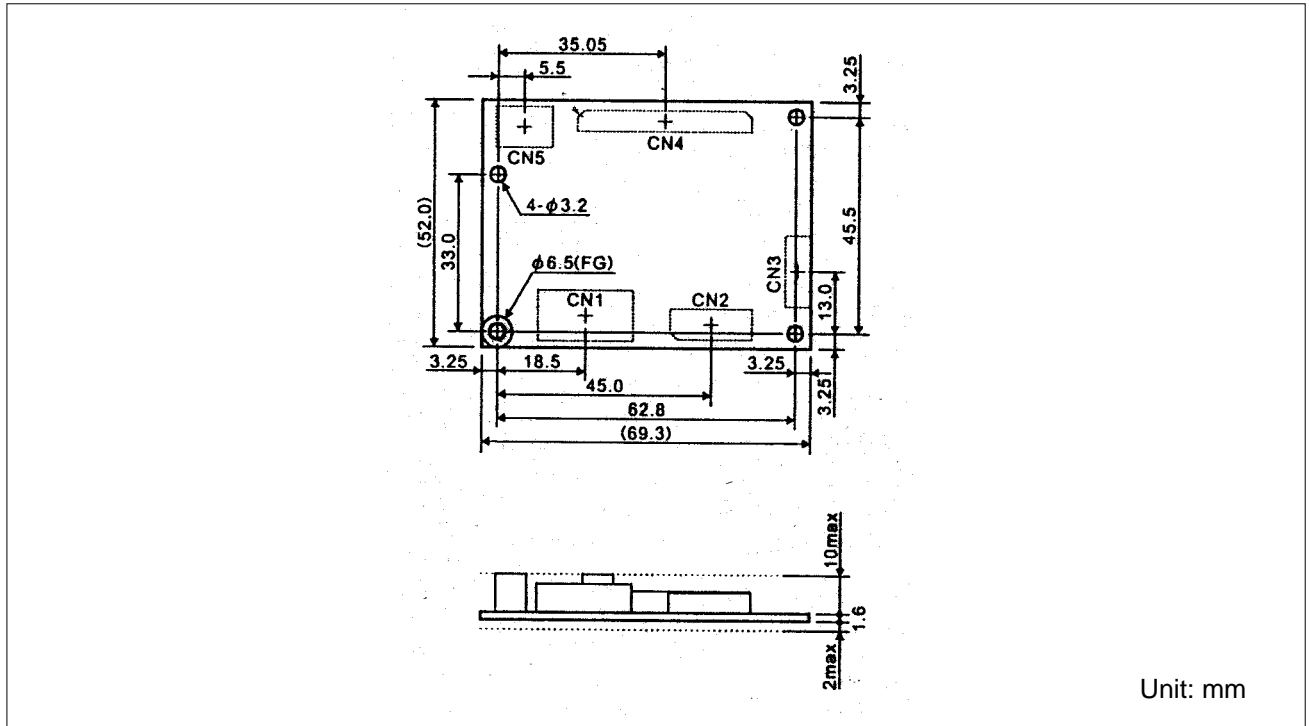

■ PRINTER CONNECTOR (FLEXIBLE PT BOARD) PIN ARRAYS

FTP-628 MCL101/103

Thermal head, control circuit side connector: 52610-3090 Molex or equivalent product

No	Signal	I/O	Contents
1	PHK	—	Cathode for photo interruptor
2	VSEN	I	paper sensor power
3	PHE	O	Emitter for photo interruptor
4	N.C. (101)/ SW1 (103)	—/I	Platen release switch
5	N.C. (101)/ SW2 (103)	—/I	Platen release switch
6	VH	—	Head drive power
7	VH	—	
8	DIN	I	Data in
9	CLK	I	Synchronous clock for communication
10	GND	—	Ground power supply for thermal head
11	GND	—	
12	STB6	I	Thermal head energizing control signal
13	STB5	I	
14	STB4	I	
15	VDD	I	Logic power
16	TH	O	Thermally sensitive resistor input terminal 1
17	TH	O	Thermally sensitive resistor input terminal 2
18	STB3	I	Thermal head energizing control signal
19	STB2	I	
20	STB1	I	
21	GND	—	Ground power supply for thermal head
22	GND	—	
23	$\overline{\text{LAT}}$	I	Data latch
24	DO	O	Data out
25	VH	I	Power supply for thermal head
26	VH	I	
27	MT/A	I	Stepping motor excitation signal
28	$\overline{\text{MT/A}}$	I	
29	MT/B	I	
30	$\overline{\text{MT/B}}$	I	

Do not plug or unplug the FPC when power is on.

Fujitsu Components International Headquarter Offices

Japan

Fujitsu Component Limited
Gotanda-Chuo Building
3-5, Higashigotanda 2-chome, Shinagawa-ku
Tokyo 141, Japan
Tel: (81-3) 5449-7010
Fax: (81-3) 5449-2626
Email: promothq@ft.ed.fujitsu.com
Web: www.fcl.fujitsu.com

North and South America

Fujitsu Components America, Inc.
250 E. Caribbean Drive
Sunnyvale, CA 94089 U.S.A.
Tel: (1-408) 745-4900
Fax: (1-408) 745-4970
Email: marcom@fcai.fujitsu.com
Web: www.fcai.fujitsu.com

Europe

Fujitsu Components Europe B.V.
Diamantlaan 25
2132 WV Hoofddorp
Netherlands
Tel: (31-23) 5560910
Fax: (31-23) 5560950
Email: info@fceu.fujitsu.com
Web: www.fceu.fujitsu.com

Asia Pacific

Fujitsu Components Asia Ltd.
102E Pasir Panjang Road
#04-01 Citilink Warehouse Complex
Singapore 118529
Tel: (65) 6375-8560
Fax: (65) 6273-3021
Email: fcal@fcal.fujitsu.com
www.fcal.fujitsu.com

© 2004 Fujitsu Components America, Inc. All company and product names are trademarks or registered trademarks of their respective owners. Rev. 03/10/2004.