

BATTERY DRIVEN, FTP-608 Series 2" HIGH SPEED THERMAL PRINTER

FTP-628MCL053/054

■ OVERVIEW

The FTP-628 MCL Series are battery driven high-speed ultracompact printers with a 2-inch paper width equivalent. Paper can be easily set using our unique platen release mechanism.

The FTP-628 MCL Series can be used for a variety of applications, such as portable terminals, POS, ticket issuing terminals, label printers, banking terminals, and measurement and medical equipment.



■ HIGHLIGHTS

- **Ultra compact**
Height 15.5 mm, width 69.6 mm, depth 34.3 mm
- **High speed printing**
It can print at 60 mm/s (480 dotlines/s) maximum by using Fujitsu's unique head drive control.
- **High resolution printing / Kanji supported**
8 dots/mm of resolution printing is possible.
- **Easy paper setting**
Our unique platen release mechanism allows a wide paper route even if the printer is ultra-compact, so paper can be easily inserted. Conventional auto loading is also available.
- **Two types of paper routes**
Front or bottom feed, depending on the paper route.
- **Easy mounting**
Wiring for the head, motor, sensor are housed within one flexible cable (053, 054) or in two cables (051, 052). The mechanism can be secured by one hook and two screws at two locations, making mounting easy.

■ PART NUMBERS

		Part Number
Printer mechanism		FTP-628MCL053 (front paper insertion with head open detection switch and knob) FTP-628MCL054 (bottom paper insertion with head open detection switch)
LSI for driving		FTP-628CU301 (ANK only)
Interface Board	Parallel	FTP-628DCL300 (Centronics)
	Serial	FTP-628DSL305 Serial (RS232C)
Interface cables	Parallel	FTP-628Y202
	Serial	FTP-628Y302
Power cable	Head, motor	FTP-628Y402

■ SPECIFICATIONS

Item	Specifications
Part number	FTP-628MCL053/054
Printing method	Thermal-line dot method
Dot structure	384 dots/line
Dot pitch (Horizontal)	0.125 mm (8 dots/mm)—Dot density
Dot pitch (Vertical)	0.125 mm (8 dots/mm)—Line feed pitch
Effective printing area	48 mm
Number of columns	ANK 32 columns/line (maximum 12 x 24 dot font)
Paper width	58 mm ⁺⁰ ₋₁
Paper thickness	60 to 100 μ m (some paper in this range may not be used because of paper characteristics)
Printing Speed	Maximum 60mm/sec. (480 dot line/sec.) at 8.5V
Character types	Alphanumeric, katakana: 159 types International and special characters: 195 types JIS Kanji level 1, level 2, non-Kanji (supported only by FTP-628DSL228, DCL208): about 6800 types
Character, dimensions (W×H), number of columns	12 × 24 dots, (1.54 × 3.0 mm), 32 columns: alphanumeric, katakana 24 × 24 dots, (3.0 × 3.0 mm), 16 columns: alphanumeric, katakana, Kanji 8 × 16 dots, (1.0 × 2.0 mm), 48 columns: alphanumeric, katakana 16 × 16 dots, (1.0 × 2.0 mm), 24 columns: alphanumeric, katakana, Kanji

■ SPECIFICATIONS

Item		Specification
Interface		Conforms to RS232C / Centronics
Power supply	For print head	4.2 - 8.5 VDC average current, 0.87 (0.93) A peak value (print ratio: 12.5%, print speed: 50mm/sec. at 7.2V)
	For motor	4.2 - 8.5 VDC, 1A maximum Note: 5.8 to 8.5 V is recommended for automatic paper loading
	For logic	5 VDC \pm 5%, 0.1 A maximum
Dimensions	Printer mechanism	72.3 x 34.3 x 15.5 mm (WxDxH)
	Interface board	69.3 x 52 x 15 mm
Weight	Printer mechanism	Approximately 47g (without knob)
	Interface board	Approximately 20g
Head life		Pulse resistance: 100 million pulses/dot (under our standard conditions) Abrasion resistance: paper traveling distance 50km (print ratio: 25% or less)
Operating environment	Operating temperature*	0° C to +50° C
	Operating humidity	20 to 85% RH (no condensation)
	Storage temperature	-20° C to +60° C (paper not included)
	Storage humidity	5 to 95% RH (no condensation)
Detection function	Head temperature detection	Detected by thermistor
	Paper out/mark detection	Detected by photo-interrupter
	Head up detection	Detected by micro-switch
Recommended thermal sensitive paper		High Sensitive Paper TF50KS-E4 (Nippon Paper)
		Standard paper: TF60KS-E(Nippon Paper) FTP-020PU001 (58mm) PD105R (Oji Paper) FTP-020P0701 (58mm)
		Medium Life Paper TF60KS-F1 FTP-020P0102 (58mm) PD170R (Oji Paper) P220VBB-1 Mitsubishi Paper)
		Long Life Paper PD160R-N (Oji Paper)

*+5°C to +40°C printing density assurance range (-25 to 70°C capability)

■ DIMENSIONS

1. Printer mechanism

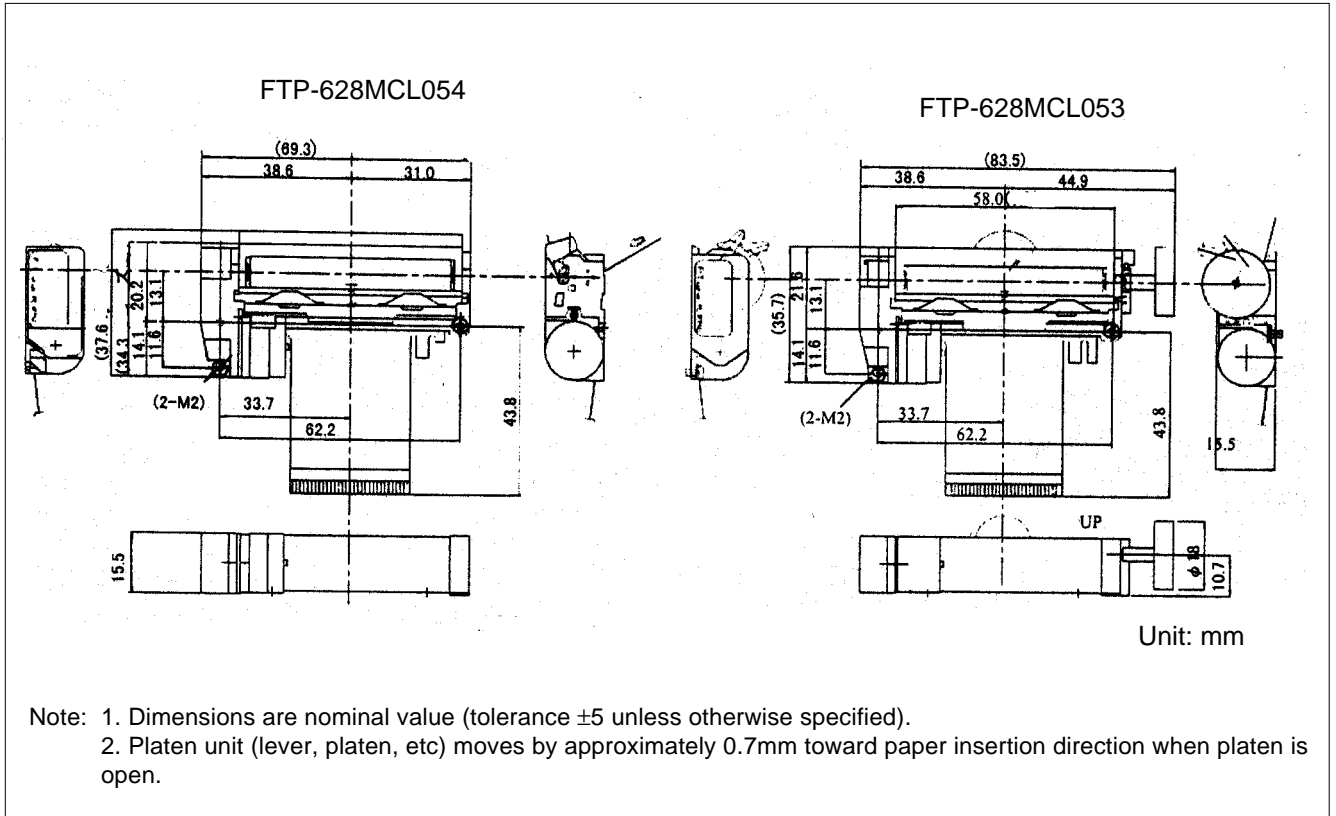

2. Interface board

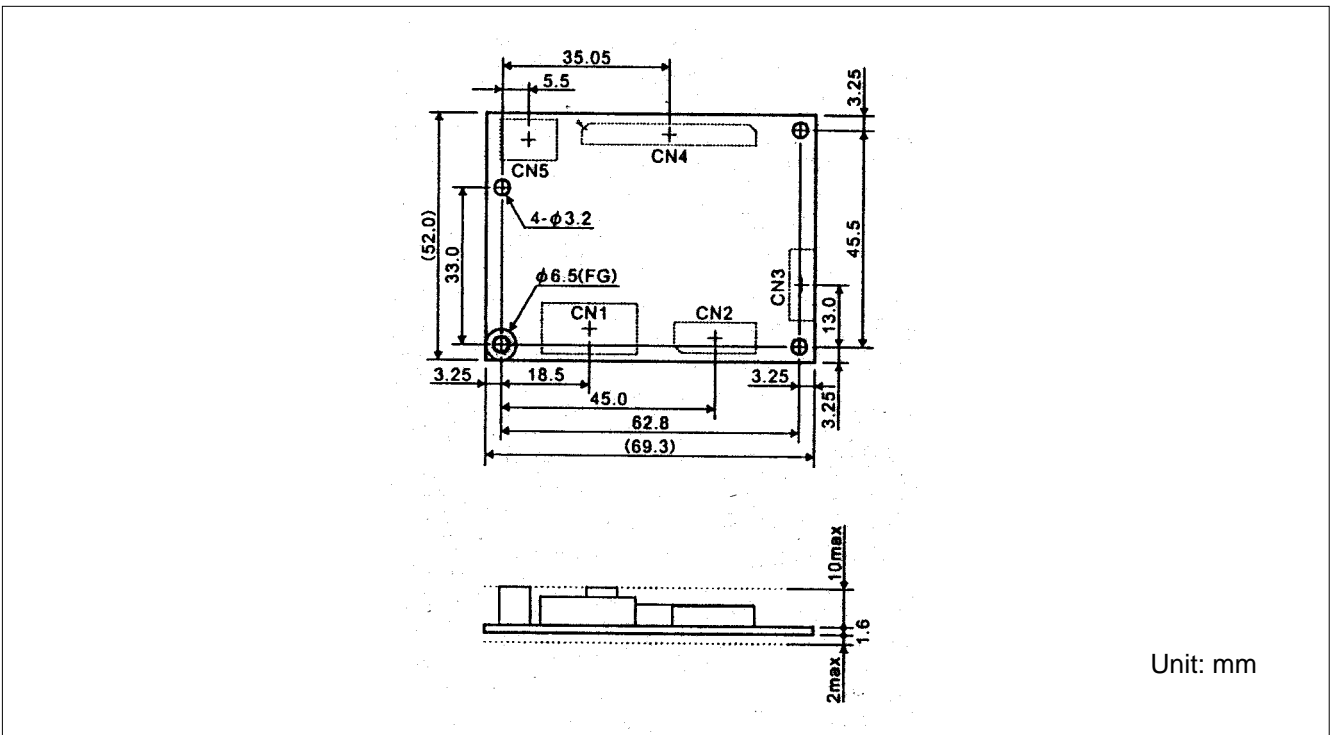

Connector (FPC) specification

(1) Connector

Mechanical unit side: FPC connector

Remote side (housing site): 52030-3090 (made by Molex)

(2) Pin assignment on the mechanical side

No	Signal	I/O	Contents
1	PHK	—	Cathode for photo interruptor
2	VSEN	I	paper sensor power
3	PHE	O	Emitter for photo interruptor
4	SW1	O	Platen release switch
5	SW2	I	Platen release switch
6	VH	I	Head drive power
7	VH	I	
8	DI	I	Data in
9	CLK	I	Synchronous clock for communication
10	GND	—	Ground power supply for thermal head
11	GND	—	
12	STB6	I	Thermal head energizing control signal
13	STB5	I	
14	STB4	I	
15	VDD	I	Logic power
16	TM	O	Thermally sensitive resistor input terminal 1
17	TM	O	Thermally sensitive resistor input terminal 2
18	STB3	I	Thermal head energizing control signal
19	STB2	I	
20	STB1	I	
21	GND	—	Ground power supply for thermal head
22	GND	—	
23	$\overline{\text{LAT}}$	I	Data latch
24	DO	O	Data out
25	VH	I	Power supply for thermal head
26	VH	I	
27	MT/A	I	Stepping motor excitation signal
28	$\overline{\text{MT/A}}$	I	
29	MT/B	I	
30	$\overline{\text{MT/B}}$	I	

■ FUNCTION OF INTERFACE BOARD

Item	Item
1. Test print function	8. Motor power saving function
2. Paper out detection	9. Mark detection function
3. Paper near end detection	10. MCU operation abnormality detection
4. Platen open detection	11. Power ON/OFF sequence protection
5. Thermal head temperature abnormality detection	12. Motor over-current protection
6. Blow-out fuse detection	13. Hardware timer
7. Head voltage abnormality detection	

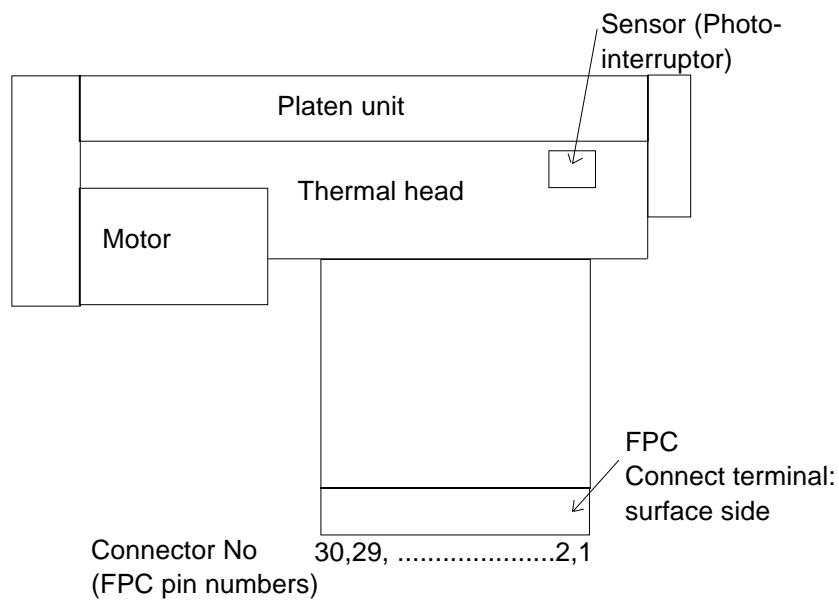

Fujitsu Components International Headquarter Offices

Japan
 Fujitsu Component Limited
 Gotanda-Chuo Building
 3-5, Higashigotanda 2-chome, Shinagawa-ku
 Tokyo 141, Japan
 Tel: (81-3) 5449-7010
 Fax: (81-3) 5449-2626
 Email: promothq@ft.ed.fujitsu.com
 Web: www.fcl.fujitsu.com

North and South America
 Fujitsu Components America, Inc.
 250 E. Caribbean Drive
 Sunnyvale, CA 94089 U.S.A.
 Tel: (1-408) 745-4900
 Fax: (1-408) 745-4970
 Email: marcom@fcai.fujitsu.com
 Web: www.fcai.fujitsu.com

Europe
 Fujitsu Components Europe B.V.
 Diamantlaan 25
 2132 WV Hoofddorp
 Netherlands
 Tel: (31-23) 5560910
 Fax: (31-23) 5560950
 Email: info@fceu.fujitsu.com
 Web: www.fceu.fujitsu.com

Asia Pacific
 Fujitsu Components Asia Ltd.
 102E Pasir Panjang Road
 #04-01 Citilink Warehouse Complex
 Singapore 118529
 Tel: (65) 6375-8560
 Fax: (65) 6273-3021
 Email: fcai@fcal.fujitsu.com
 Web: www.fcal.fujitsu.com