



# PRODUCTS RECYCLE

FUJITSU TAKAMISAWA COMPONENT LIMITED have a basic idea of  
**“SAVING ENVIROMENT AND PERFORM BETTER ENTERPRISE ACTIVITIES”**  
 and we are promoting environmental management based on ISO14001.  
 The composition parts table of the product (following) is showed, Please refer recycling.

## FTP-632MCL353/354 MATERIALS LIST

No.	PARTS NAME	MATERIALS
1	Printer frame	PPO resin (included GF)
2	Gear cover	POM resin
3	Robber roller	Silicon rubber +SUS
4	Gear	POM resin
5	Pulse motor	Iron + Copper wire
6	Motor earth board	SUS
7	Sensor attachment board	ABS resin
8	Knob	ABS resin
9	Arm	SUS
10	Head up arm	A Zinc Alloy
11	Head up lever	POM resin
12	Thermal head	Aluminum + Ceramics Substrate + PI
13	Head press shaft	SUS
14	Head support board	SPCC
15	Head press spring	SUS
16	Arm spring	SUS
17	Spring (only MCL353)	SUS
18	Pinch roller (only MCL353)	POM resin
19	Bearing	Sintering Alloy
20	Earth coil spring	SUS
21	Guide film (only MCL353)	PET resin
22	Cover film	PET resin
23	FFC	_____
24	Auto cutter	*1)

\*1)Please refer to specifications of FTP-632CT004

### “Abbreviation Of Materials”

SUS : Stainless Used Steel	POM : Polyacetal
PET : Poly(ethylene terephthalate)	GF : Glass Fiber
SPCC : Rolling steel sheet	PPO : Polyphenylene Oxide
PI : Polyimide	

DOCUMENT CONTROL SECTION

DATE

				TITLE FTP-632MCL353/354 PRODUCT SPECIFICATIONS	
				DRAW No. A1NA02242-0353/6	
				CUST	
EDIT	DATE	DESIGN	CHECK	DESCRIPTION	
DESIGN			CHECK	APPRY	FUJITSU TAKAMISAWA COMPONENT LIMITED
					RIIETE 2/2



#### 4. GENERAL SPECIFICATIONS

ITEM		SPEISIFICATION
Printing specifications	Printing method	Thermal sensitive line dot method
	Effective printing width	72mm
	Head configuration	576dots / line
	Dot pitch	0.125(vertical direction) x 0.125(horizontal direction)
	Print density	OD 0.8 or higher at the F&T standard printing condition when the specified paper is used. *Measuring instrument : SAKURA densitometer PDA-65 from Konica Co.,Ltd.
	Printing speed	At 24V drive and standard paper Maximum 80mm / second (640 dot lines / second) At F&T high-speed printing mode. Maximum 100mm / second (800 dot lines / second) At F&T high-speed collective image printing mode.
Specified paper(*1)	High-sensitivity paper	TF50KS-E4 NIPPON PAPER
		Standard paper
	Medium-term preservable paper	TF60KS-F1 NIPPON PAPER
		P220VBB-1 MITSUBISHI PAPER
		PD170R OJI PAPER
	Long-term preservable paper	TP50KJ-R NIPPON PAPER
		AFP-235 MITSUBISHI PAPER
		PD160R OJI PAPER
	2-color paper	PB770 (blue and black) MITSUBISHI PAPER
		PB670 (red and black) MITSUBISHI PAPER
Paper width		MCL353 : 80 <sup>+0.1</sup> mm (front insertion) MCL354 : 85 <sup>+0.1</sup> mm (rear insertion)
Paper feed method		Friction feed (1 dot line / 4 pulse, bipolar 1-2 phase excitation)
Paper feed accuracy		±5% at fixed-speed feed with the back tension of approx.100g(0.98N) (±2% at 25°C and 60%RH)
Line gap in one print line by enable drive		Gap between right and left print line in the same line dot line : 0.125mm
Detection function	Head temperature detection	Thermistor
	Paper detection	Photointerrupter
	Mark detection	
	Head up detection	Microswitch
Home-position detection		Microswitch
External dimensions(W x D x H)		116.9mm x 56.5mm x 37.7mm (excluding the lever and knob)
Mass		Approx. 340g

\*1 For using unspecified paper, both sides shall consult and evaluate and check it to determine whether to use it.

DOCUMENT CONTROL SECTION

DATE

					TITLE FTP-632MCL353/354 PRODUCT SPECIFICATIONS	
					DRAW No. A1NA02242-0353/6	
					CUST	
EDIT	DATE	DESIGN	CHECK	DESCRIPTION		
DESIGN			CHECK	APPRY	FUJITSU TAKAMISAWA COMPONENT LIMITED	4/4

A

B

C

D

A

B

C

D

E

F

ITEM			SPEIFICATION
Operating power	Head	For printing	Voltage : 24 VDC ±5% Current : peak current of approx.2.2A(2-part divided drive, Printing rate : 50%, printing speed : 80mm/sec, head resistance value : 1500 Ω)
		For logic	Voltage : 5 VDC ±5% Current : Maximum 0.2A
	Motor drive		Voltage : 24 VDC ±5% Current : Maximum 1.0A (by the F&T standard constant-current drive circuit)
Environmental characteristics	Operating temperature and humidity(*2)		5°C to 40°C, 20 to 85%RH No condensation
	Storage temperature and humidity		-20°C to 60°C, 5 to 95%RH No condensation paper is excluded
	Noise		60 dB or less at 1m from the surface of the printing mechanism
Reliability (*3)	Vibration (non-operation)		10 to 55 to 10 Hz, one-side amplitude 0.15mm,1 octave/minute, maximum 1m/s <sup>2</sup> 20 cycles for each of X, Y, and Z directions
	Impact (non-operation)		50m/s <sup>2</sup> , 11ms, half-sine wave, 5 times for each of the X, Y, and Z directions
	Pack drop		75cm drop for 6 surface, corner and ridges in pack
	Temperature and humidity cycle (non-operation)		Two successive cycles of -25°C (2 hours) to room temperature (2 hours) to 65°C and 85% RH (2hours) to room temperature (2hours)
Life		Electrical life	1 hundred million pulses (at the F&T standard printing condition)
		Mechanical life	Paper length : 50 km (printing rate : 25% or less)
	Life of the head up lever		5000 or more times when one up and down are counted as one time
	Photointerrupter life		1.2 x 10 <sup>4</sup> hours (time while the current is conducted) with the specified circuit
	Cutting life		500 thousand times or more(cutting cycle is 2 s or longer)
Printing start position at the left end			MCL353 : 4±2 mm , MCL354 : 6.5±2 mm from the paper edge to the print start position. This value is : 1) When the paper of 80mm (MCL353) and 85mm (MCL354) width is used 2) When 1-ply long-term perceivable paper is used 3) When no paper jam or collapse occurs
Paper positioning by mark detection			Approx. 7.5mm (MCL353) and 10.2mm (MCL354) from the mark end position to heating element. This value is when paper is inserted from front, fixed-speed feed is used, and paper feeding by marking detection is the default (2mm).

\*2 The print density is guaranteed in this range. The printer can operate from 5°C to 50°C.

\*3 After the test, the printing specifications shall be satisfied.

DOCUMENT CONTROL SECTION

DATE

					TITLE FTP-632MCL353/354 PRODUCT SPECIFICATIONS	
					DRAW No. A1NA02242-0353/6	
					CUST	
EDIT	DATE	DESIGN	CHECK	DESCRIPTION		
DESIGN			CHECK	APPRY	FUJITSU TAKAMISAWA COMPONENT LIMITED	
					RISE	5/5

# 5. EXTERNAL DIMENSIONS AND MOUNTING POSITIONS

## (1) External dimensions

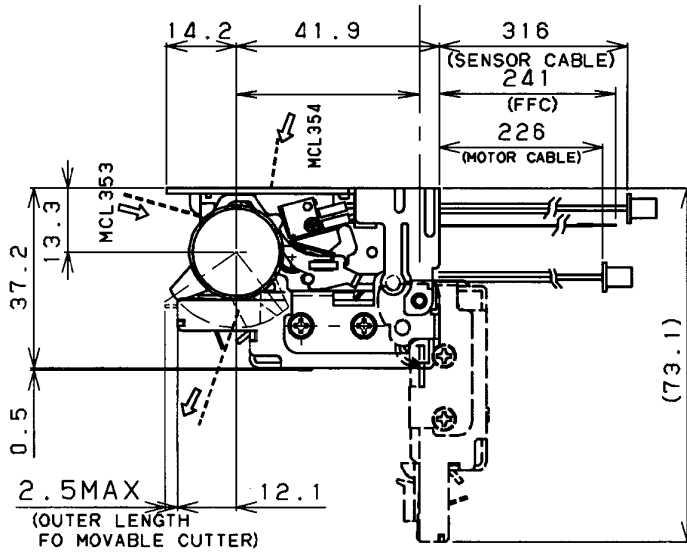

Note  
 1. The dimensions is typical dimensions.  
 2. The \* mark dimensions is stick out.  
 (3-M3.0 screw)  
 3. The ⊙ mark is daum line abd the cutter unit is support shaft.

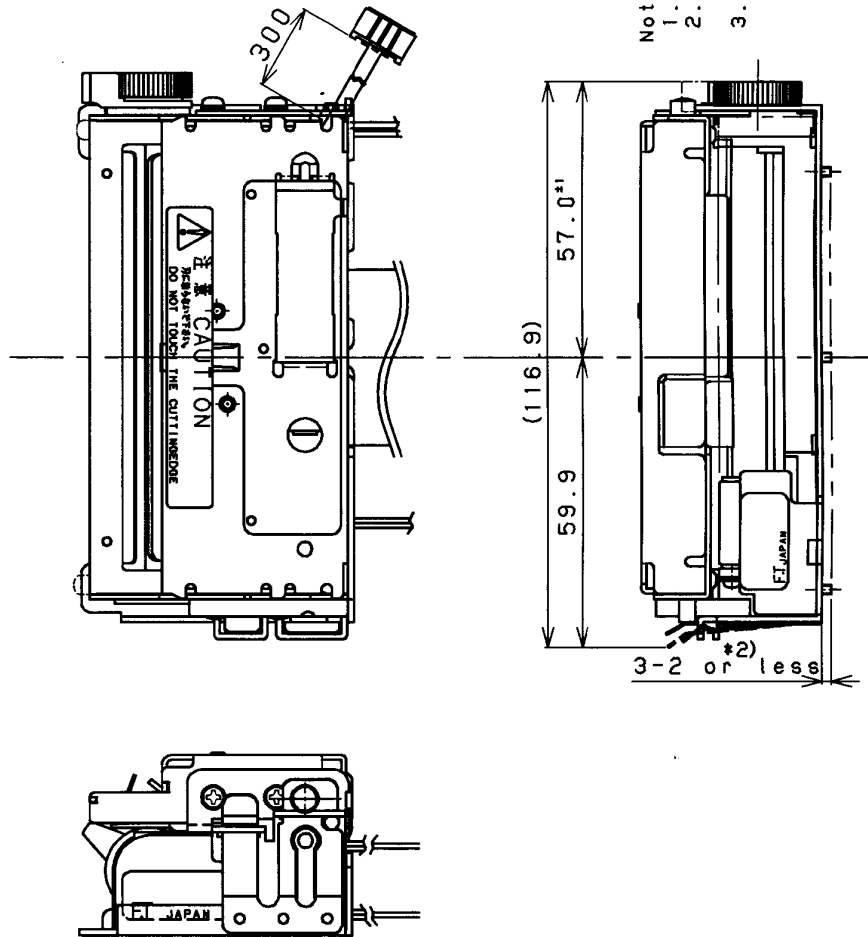

(UNIT : mm)

Figure 2 FTP-632MCL353/354 outview dimensions

DATE	DOCUMENT CONTROL SECTION
------	--------------------------

					TITLE FTP-632MCL353/354	
					PRODUCT SPECIFICATIONS	
					DRAW No. A1NA02242-0353/6	
					CUST	
EDIT	DATE	DESIGN	CHECK	DESCRIPTION		
DESIGN			CHECK	APPRY	FUJITSU TAKAMISAWA COMPONENT LIMITED	
					6	6

(2) Mounting Positions

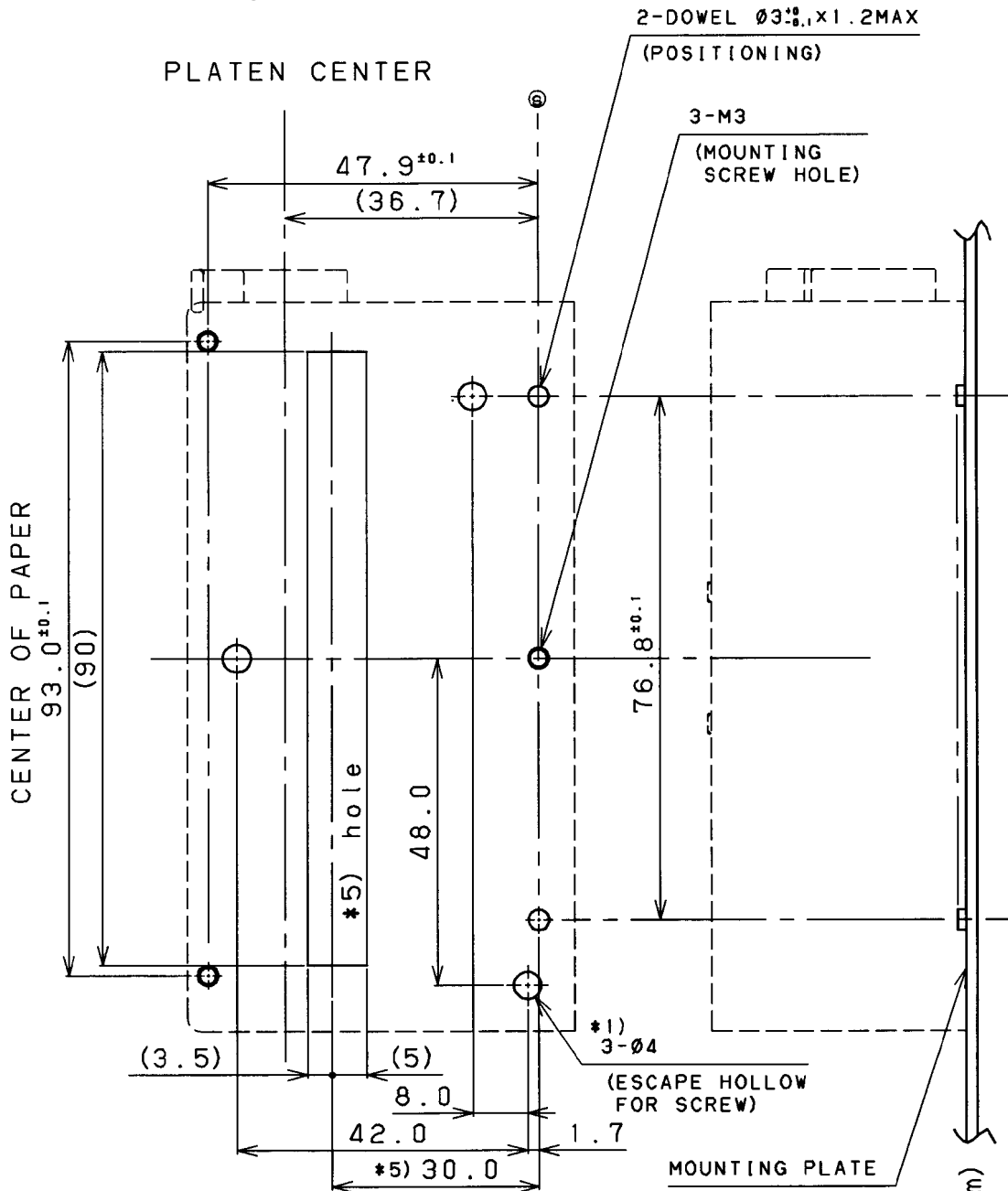

NOTES)

1. Please make hollow of  $\varnothing 4 \times 2$ mm in order to escape screw projection in three positions.
2. The dimension tolerance is  $\pm 0.15$ mm unless specified.
3. This drawing is seen from the upper side of the printer.
4. The flatness of printer mounting plate shall be within 0.1mm.
5. \*dimension is the center of paper entrance for MCL354. The shape of entrance is reference dimension, which dose not touch to paper.
6.  $\oplus$  shows an installation standard line of this printer.
7. Please use three screws of M3 when you install the printer.

Figure 3 FTP-632MCL353/354 mounting dimensions

DOCUMENT CONTROL SECTION

DATE

				TITLE FTP-632MCL353/354	
				PRODUCT SPECIFICATIONS	
				DRAW No. A1NA02242-0353/6	
				CUST	
EDIT	DATE	DESIGN	CHECK	DESCRIPTION	
DESIGN			CHECK	APPRY	FUJITSU TAKAMISAWA COMPONENT LIMITED
				REV	7/7

### 6. CONNECTOR SPECIFICATIONS

#### 6.1 Thermal head

##### (1) Connector used

Mechanical unit side : IL-FPC-28CLIP (made by JAE)

Remote side (housing) : 52045-2810 (made by Morex) or equivalent  
1.25mm pitch FFC

##### (2) Pin assignment on the mechanical unit side

No.	SYMBOL	SIGNAL NAME
1	VH	Head drive power
2	VH	Head drive power
3	VH	Head drive power
4	VH	Head drive power
5	DO	Data output
6	CLK	Clock
7	LAT	Data latch
8	STB2	Strobe 2
9	STB1	Strobe 1
10	TH(*1)	Thermistor
11	GND	Ground for head
12	GND	Ground for head
13	GND	Ground for head
14	GND	Ground for head
15	GND	Ground for head
16	GND	Ground for head
17	GND	Ground for head
18	GND	Ground for head
19	GND	Ground for head
20	TH(*1)	Thermistor
21	VDD	Logic power
22	STB4	Strobe 4
23	STB3	Strobe 3
24	DIN	Data input
25	VH	Head drive power
26	VH	Head drive power
27	VH	Head drive power
28	VH	Head drive power

\*1 one end of thermistor is connected to the ground

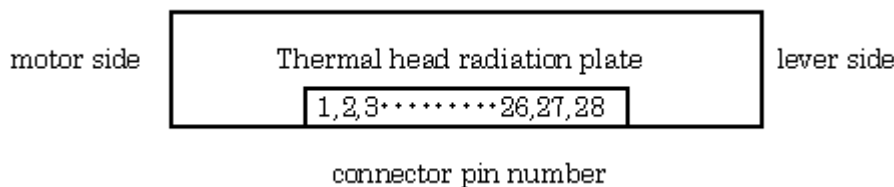

DOCUMENT CONTROL SECTION

DATE

				TITLE FTP-632MCL353/354	
				PRODUCT SPECIFICATIONS	
				DRAW No. A1NA02242-0353/6	
				CUST	
EDIT	DATE	DESIGN	CHECK	DESCRIPTION	
DESIGN			CHECK	APPRY	FUJITSU TAKAMISAWA COMPONENT LIMITED
					8/8

(3) Notes

- 1) Pull up the four strobe signals with about 4.7kΩ.
- 2) Pull down the latch, data input, and clock signals with 22kΩ.
- 3) Don't connect or disconnect a connector with the power turned on.
- 4) Please note handling enough because the connector is installed directly on the thermal head substrate.
- 5) Don't connect or disconnect a connector 6 or more times.
- 6) Don't strain connector.
- 7) Please do not bend FFC in the reinforcement board (blue part) and the root. It causes defective contact.
- 8) Please avoid the wiring for FFC around the high temperature (80°C or more) of the place.
- 9) Once FFC is bent, do not rework(straighten or bend backward).

6.2 Paper feed motor

(1) Connectors used

Motor side (housing) : PHR-4 (made by J.S.T) or equivalent  
 Remote side : B4B-PH-K-S (made by J.S.T) or equivalent

(2) Pin assignment on the motor side

No.	SYMBOL	SIGNAL NAME
1	$\overline{B}$	Excitation signal $\overline{B}$
2	$\overline{B}$	Excitation signal $\overline{B}$
3	$\overline{A}$	Excitation signal $\overline{A}$
4	A	Excitation signal A

6.3 Sensor connector

(1) Connectors used

Sensor side (housing) : PHR-5 (made by J.S.T) or equivalent  
 Remote side : B5B-PH-K-S (made by J.S.T) or equivalent

(2) Pin assignment on the sensor side

No.	SYMBOL	SIGNAL NAME
1	VSEN	Power for the paper sensor
2	PHE	Photointerrupter emitter
3	PHK	Photointerrupter cathode
4	SW1	Head up detection switch 1
5	SW2	Head up detection switch 2

DOCUMENT CONTROL SECTION

DATE

				TITLE FTP-632MCL353/354	
				PRODUCT SPECIFICATIONS	
				DRAW No. A1NA02242-0353/6	
				CUST	
EDIT	DATE	DESIGN	CHECK	DESCRIPTION	
DESIGN			CHECK	APPRY	
				FUJITSU TAKAMISAWA COMPONENT LIMITED	
				9/9	

**7. THERMAL HEAD SPECIFICATIONS**

(1) General characteristics

- 1) Method : Thermal line dot method
- 2) Total number of dot : 576dots / line
- 3) Heating resistance element dot pitch : 0.125mm
- 4) Heating element average resistance value : 1500Ω±3%

(2) Maximum rating

- 1) Maximum voltage applied : 26.4V
- 2) Maximum energy applied : 0.50 mJ/dot  
(Vset=24.0 V, Ton=0.95 ms, Tcy=2.5ms)
- 3) Maximum board temperature : 65°C (thermistor temperature)
- 4) Maximum number of concurrently energized dots : 288 dots

(3) Electrical characteristics

- 1) Electrical characteristics : table 1
- 2) Timing chart : Figure 4
- 3) Electric circuit block diagram : Figure 5
- 4) Equivalent circuit : Figure 6
- 5) Driver configuration : 144 bits x 4 drivers
- 6) Data transfer method : signal-input serial transfer
- 7) Data input frequency : 4.0 MHz or lower
- 8) Printing method : independent 4 enable method

(4) Electrical operating conditions (at normal rating : 25°C, Rav = 1500Ω, 288 concurrently energized dots)

- 1) Power applied (Po) : 0.340 W/dot
- 2) Width of pulse applied (Ton) : 1.07msec
- 3) Energy applied (Eo) : 0.36 mJ / dot (25°C)
- 4) Printing cycle period : 2.5 msec (at 25°C, 2-part divided drive)

This can be shorten by using self-hysteresis method

- 5) Voltage applied (VH) : 24.0V
- 6) Current consumption : 4.3 A (peak value at 24.0 V)

Notes :

Energy calculation formula

$$P = I_o^2 \times R_{av} = \frac{V_{set}^2 \times R_{av}}{(R_{com} + N + R_{av} + R_{ic} + R_{lead})^2}$$

$$T_{on} = E_o / P_o \quad \text{or} \quad P_o = E_o / T_{on}$$

DOCUMENT CONTROL SECTION

DATE

					TITLE FTP-632MCL353/354	
					PRODUCT SPECIFICATIONS	
					DRAW No. A1NA02242-0353/6	
					CUST	
EDIT	DATE	DESIGN	CHECK	DESCRIPTION		
DESIGN			CHECK	APPRY	FUJITSU TAKAMISAWA COMPONENT LIMITED	
					FILE	10/10

$$V_{set} = (P_o / R_{av}) \times (R_{com} \times N + R_{av} + R_{ic} + R_{lead})$$

Rav	:Average resistance	example	1500 Ω
N	:Number of impressed dots simultaneously	example	288 dots
Rcom	:Common resistance		0.075 Ω
Ric	:Driver-on resistance		70Ω
Rlead	:Lead resistance		14Ω

(5) Thermistor characteristics

- 1) Thermistor constant (B) :3950 k ± 2%
- 2) Resistance value R25 : 30 kΩ ± 5% (at 25°C)
- 3) Operating temperature range : -20 to 80°C
- 4) Heat time constant : within 30 seconds (in air)
- 5) Temperature characteristics :  $R_X = R_{25} \times \text{EXP}\{ B \times (1/T_X - 1/T_{25}) \}$   
( T = Absolute temperature)

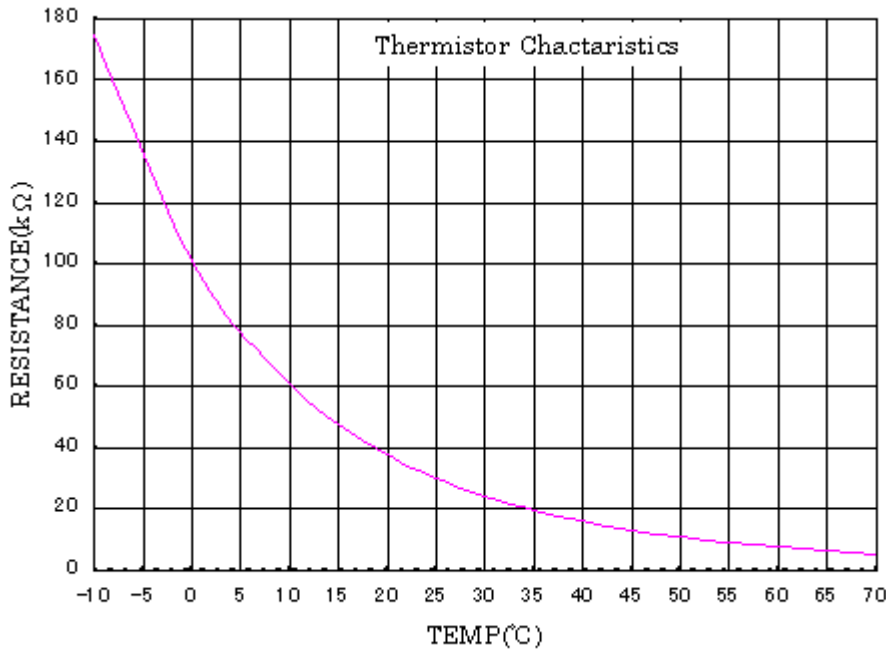

Figure 3 Temperature characteristics of thermistor

DATE DOCUMENT CONTROL SECTION

					TITLE FTP-632MCL353/354	
					PRODUCT SPECIFICATIONS	
					DRAW No. A1NA02242-0353/6	
					CUST	
EDIT	DATE	DESIGN	CHECK	DESCRIPTION		
DESIGN			CHECK	FUJITSU TAKAMISAWA COMPONENT LIMITED		
						11 / 11

Table 1 Electrical characteristics

ITEM	SYMBOL	MINIMUM	TYPICAL	MAXIMUM	UNIT	CONDITION
Print power supply voltage	VH		24.0	26.4	V	
Circuit power supply voltage	Vdd	4.75	5.00	5.25	V	
Circuit power supply current	Idd			24	mA	fDI=Fclk/2
Input voltage	VIH	0.8 x VDD		VDD	V	STB,DI,LAT,CLK
	VIL	0.0		0.2 x VDD	V	STB,DI,LAT,CLK
Data input current	I <sub>IH</sub> DI			0.5	μA	VIH=5V
	I <sub>IL</sub> DI			-0.5	μA	VIL=0V
STB input current	I <sub>IH</sub> STB			0.5	μA	
	I <sub>IL</sub> STB			-30	μA	
Clock input current	I <sub>IH</sub> CLK			2	μA	
	I <sub>IL</sub> CLK			-2	μA	
Latch input current	I <sub>IH</sub> LAT			2	μA	
	I <sub>IL</sub> LAT			-2	μA	
Data out	VDOH	4.45			V	Open,Vdd=4.5V
	VDOL			0.05	V	
Output voltage	VOL		(1.0)		V	
Clock frequency	fCLK			4	MHz	Figure 4
Width of clock pulse	tw CLK	120			ns	
Data setup time	tsetup DI	50			ns	Same as above
Data hold time	Thold DI	50			ns	Same as above
Dataout delay time	td DO			500	ns	Same as above
Latch pulse width	tw LAT	100			ns	Same as above
Latch setup time	tsetup LAT	200			ns	Same as above
Latch hold time	Thold LAT	50			ns	Same as above
STB setup time	tsetup STB	300			ns	Same as above
Output delay time	t <sub>do</sub>			5	μs	Same as above

DOCUMENT CONTROL SECTION

DATE

				TITLE FTP-632MCL353/354 PRODUCT SPECIFICATIONS	
				DRAW No. A1NA02242-0353/6	
				CUST	
EDIT	DATE	DESIGN	CHECK	DESCRIPTION	
DESIGN			CHECK	APPRY	
				FUJITSU TAKAMISAWA COMPONENT LIMITED	
				RII	12/12

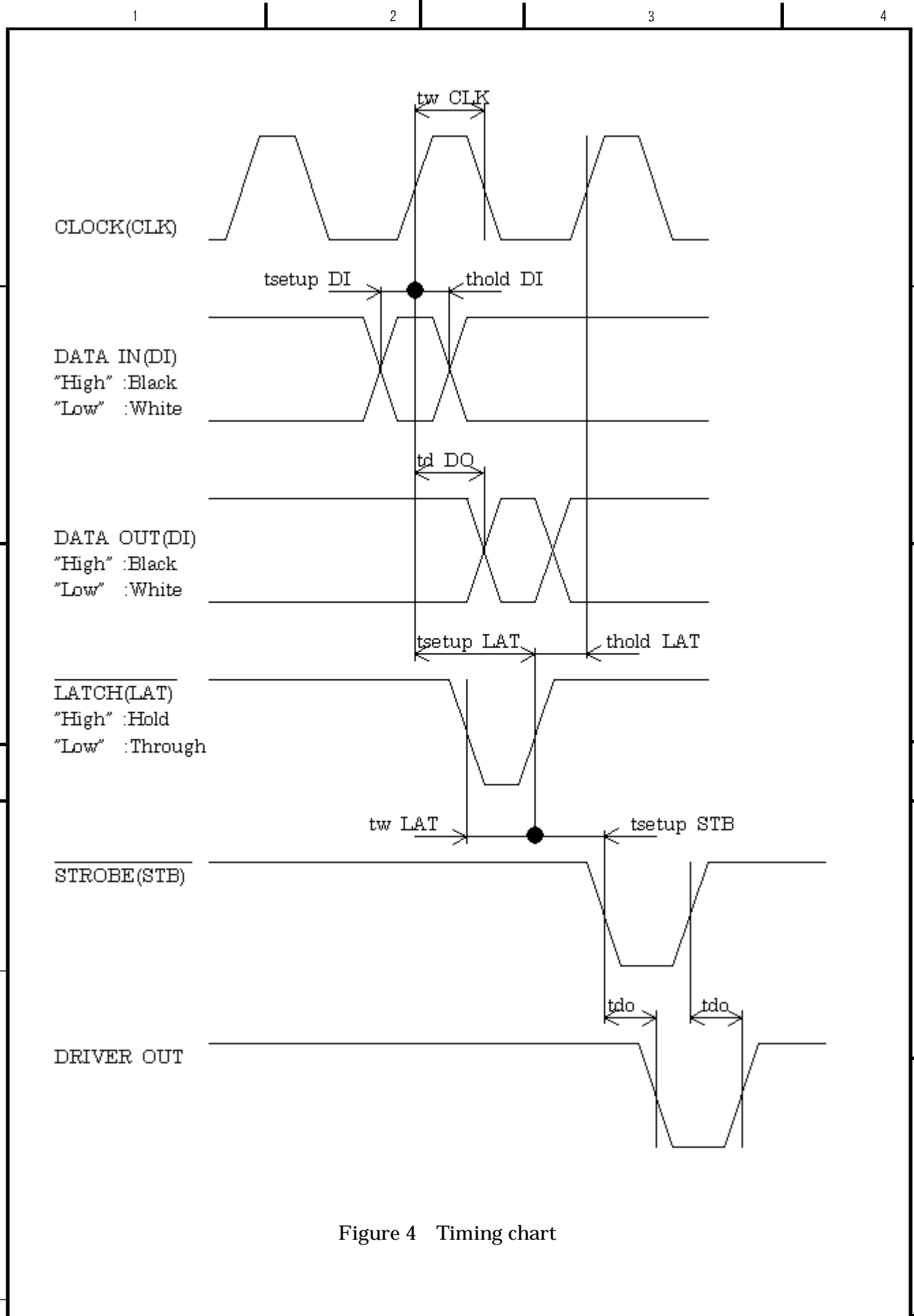
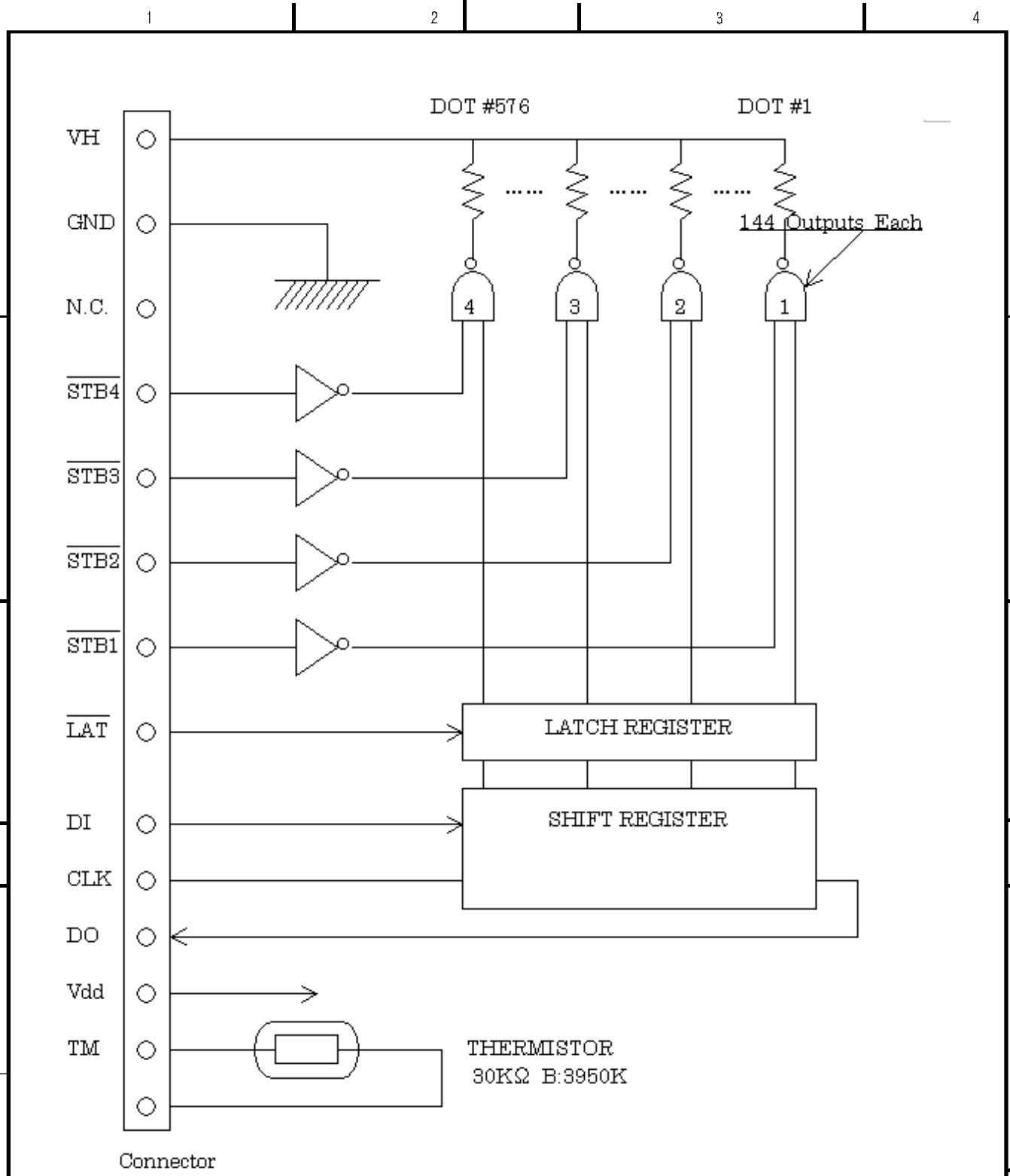

Figure 4 Timing chart

DOCUMENT CONTROL SECTION

DATE

					TITLE FTP-632MCL353/354	
					PRODUCT SPECIFICATIONS	
					DRAW No. A1NA02242-0353/6	
					CUST	
EDIT	DATE	DESIGN	CHECK	DESCRIPTION		
DESIGN			CHECK	APPRY	FUJITSU TAKAMISAWA COMPONENT LIMITED	13/13



STB No.	DOT No.	dots/STB
1	1 to 144	144
2	145 to 288	144
3	289 to 432	144
4	433 to 576	144

Figure 5 Equivalent circuit diagram

DOCUMENT CONTROL SECTION

DATE

				TITLE FTP-632MCL353/354	
				PRODUCT SPECIFICATIONS	
				DRAW No. A1NA02242-0353/6	
				CUST	
EDIT	DATE	DESIGN	CHECK	DESCRIPTION	
DESIGN			CHECK	APPRY	
				FUJITSU TAKAMISAWA COMPONENT LIMITED	
				REV	14/14

A. At standard drive

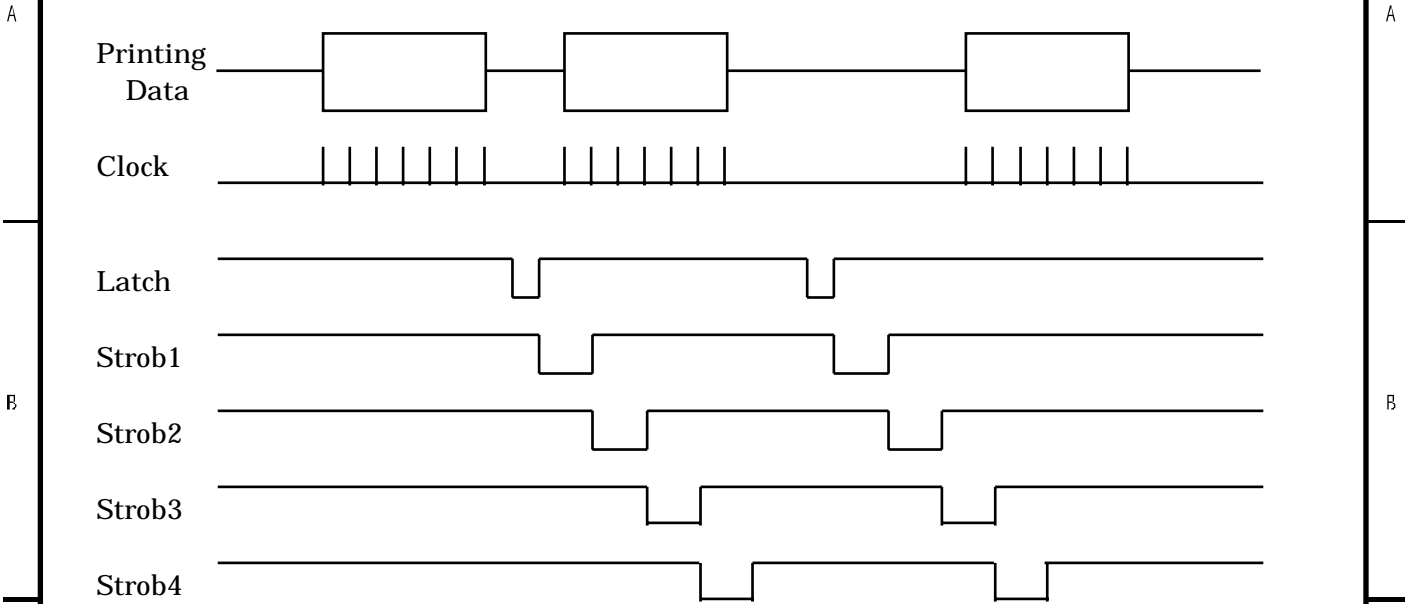

B. At high-speed drive

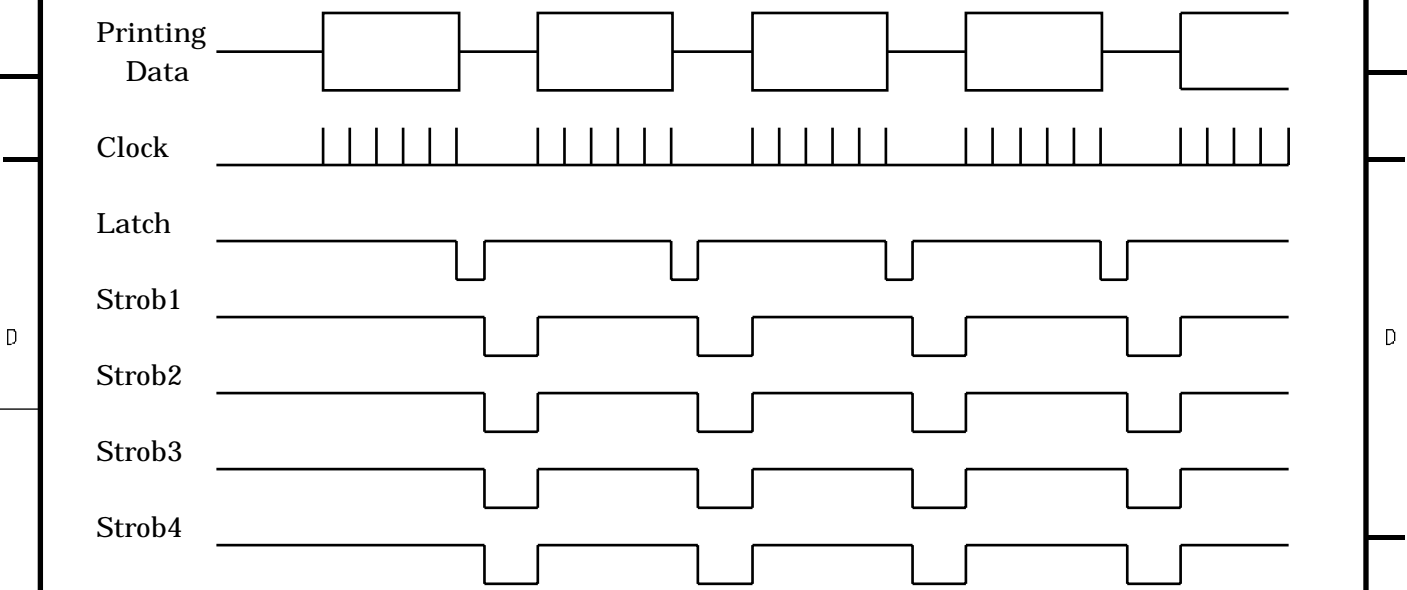

Notes ) The head current consumption increase at high-speed drive.

Figure 6 Control timing

DATE DOCUMENT CONTROL SECTION

					TITLE FTP-632MCL353/354	
					PRODUCT SPECIFICATIONS	
					DRAW No. A1NA02242-0353/6	
					CUST	
EDIT	DATE	DESIGN	CHECK	DESCRIPTION		
DESIGN			CHECK	APPRY	FUJITSU TAKAMISAWA COMPONENT LIMITED	15/15

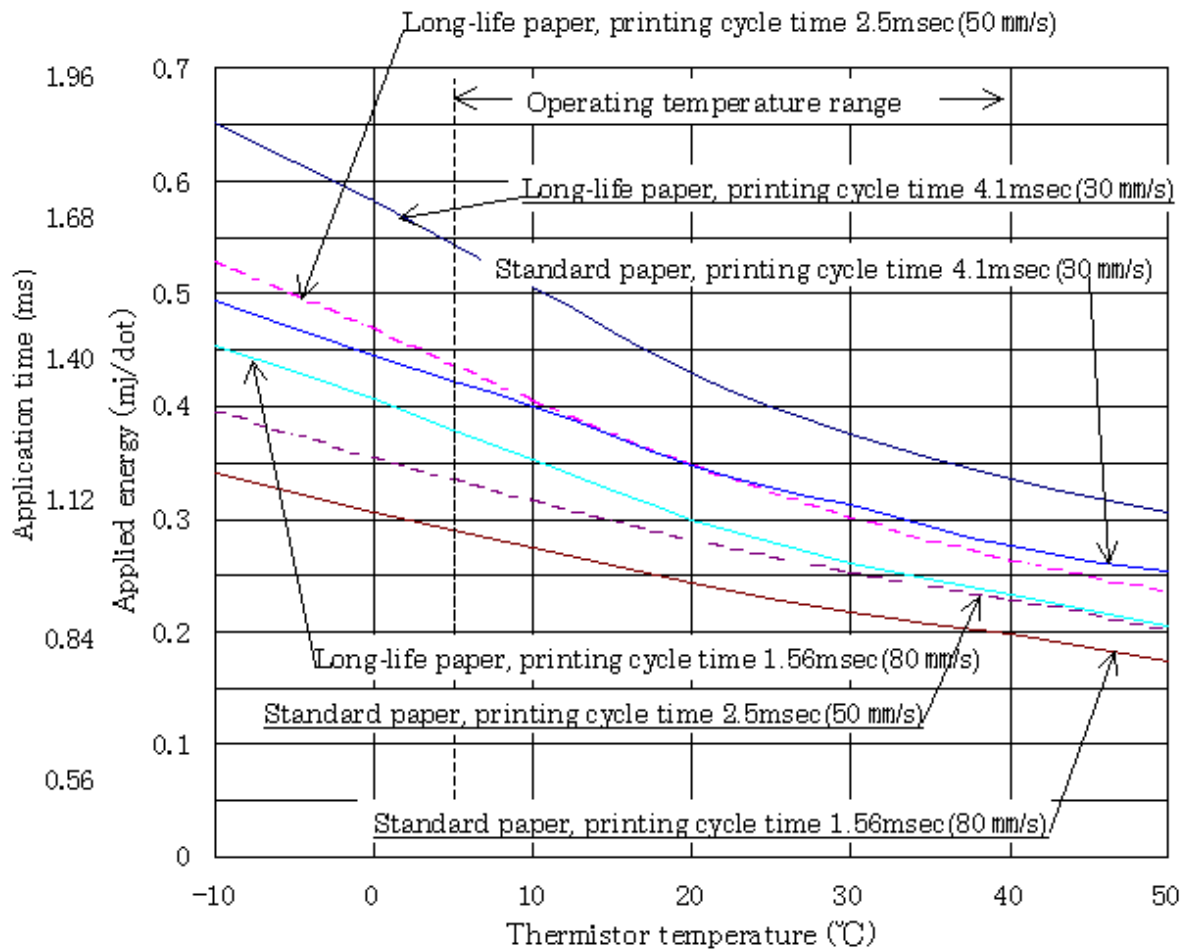

Temperature-applied energy characteristics of FTP-6x2MCL series

Condition

Head supply voltage : 24V

Standard paper : PD150R

Long-life paper : AFP-235

DATE	DOCUMENT CONTROL SECTION
	↑

					TITLE FTP-632MCL353/354	
					PRODUCT SPECIFICATIONS	
					DRAW No. A1NA02242-0353/6	
					CUST	
EDIT	DATE	DESIGN	CHECK	DESCRIPTION		
DESIGN			CHECK	APPRY	FUJITSU TAKAMISAWA COMPONENT LIMITED	16 / 16

Temperature characteristics of FTP-6x2MCL series thermistor and application width

Temperature	Thermistor resistance value (kΩ)	Printing speed 80 mm/sec		Printing speed 50 mm/sec		Printing speed 30 mm/sec	
		Applica-Tion width(ms)	Energy (mj)	Applica-tion width(ms)	Energy (mj)	Applica-tion width(ms)	Energy (mj)
0	100.99	0.867	0.310	1.009	0.360	1.245	0.445
5	77.85	0.822	0.294	0.956	0.342	1.180	0.422
10	60.57	0.777	0.278	0.904	0.323	1.116	0.399
15	47.53	0.732	0.262	0.852	0.304	1.052	0.376
20	37.61	0.682	0.244	0.794	0.284	0.980	0.350
25	30.00	0.638	0.228	0.742	0.265	0.916	0.327
30	24.11	0.598	0.214	0.696	0.249	0.859	0.307
35	19.51	0.563	0.201	0.655	0.234	0.808	0.289
40	15.89	0.538	0.192	0.626	0.224	0.773	0.276
45	13.03	0.513	0.183	0.597	0.213	0.737	0.263
50	10.75	0.493	0.176	0.574	0.205	0.708	0.253
55	8.92	0.478	0.171	0.556	0.199	0.687	0.245
60	7.45	0.463	0.165	0.539	0.193	0.665	0.238
65	6.25	0.453	0.162	0.527	0.188	0.651	0.233
70	5.27	0.438	0.156	0.510	0.182	0.630	0.225
75	4.47	0.433	0.155	0.504	0.180	0.622	0.222
80	3.80	0.423	0.151	0.493	0.176	0.608	0.217

“Condition”

Supply voltage : 24 V  
 Paper : Standard paper (PD150R)  
 Average resistance value : 1500 Ω

DOCUMENT CONTROL SECTION

DATE

				TITLE FTP-632MCL353/354	
				PRODUCT SPECIFICATIONS	
				DRAW No. A1NA02242-0353/6	
				CUST	
EDIT	DATE	DESIGN	CHECK	DESCRIPTION	
DESIGN			CHECK	APPRY	
				FUJITSU TAKAMISAWA COMPONENT LIMITED	
				17/17	

(6) Notes for use

A

- 1) For successive printing with a high printing rate, make control so that the head board (thermistor) temperature doesn't exceed the specified value.
- 2) Control so that VH is turned off is recommended when the device is at standby because ion, noise, etc. may damage the thermal head.
- 3) Make control so that the thermal head isn't overheated when the line to the thermistor is cut.
- 4) Don't input pulse noise that exceeds 2V and 20ns to any signal pin.
- 5) The length and resistance of the wiring from VH and GND to the thermal head shall be 300mm and 15mΩ. This wiring is recommended to be separated from other signal line in the design.
- 6) Control the CLK, LAT, DIN, and STB signals by C-MOS(74HC240 or equivalent).
- 7) Turn on the power in the VDD to VH order, and turn off the power in the VH to VDD order.

B

C

D

DATE	DOCUMENT CONTROL SECTION
	↑

					TITLE FTP-632MCL353/354	
					PRODUCT SPECIFICATIONS	
					DRAW No. A1NA02242-0353/6	
					CUST	
EDIT	DATE	DESIGN	CHECK	DESCRIPTION		
DESIGN			CHECK	APPRY	FUJITSU TAKAMISAWA COMPONENT LIMITED	18 / 18

### 8. STEPPING MOTOR SPECIFICATIONS

(1) General specifications (motor as s signal unit)

ITEM	SPECIFICATIONS
Type	Permanent magnetic type
Number of phases	2 phase (bipolar specifications)
Step angle	9° at 1-2 phase excitation
Coil resistance / phase	6.0Ω±10%
Rated voltage	24VDC

(2) Stepping motor drive method

- 1) Drive the stepping motor by bipolar 1-2 phase excitation.
- 2) Number of steps per dot line printed.

EXCITATION METHOD	NUMBER OF STEPS	ROTATION ANGLE
1-2 phase excitation	4	9 degrees / step

3) The excitation method for reference is shown below.

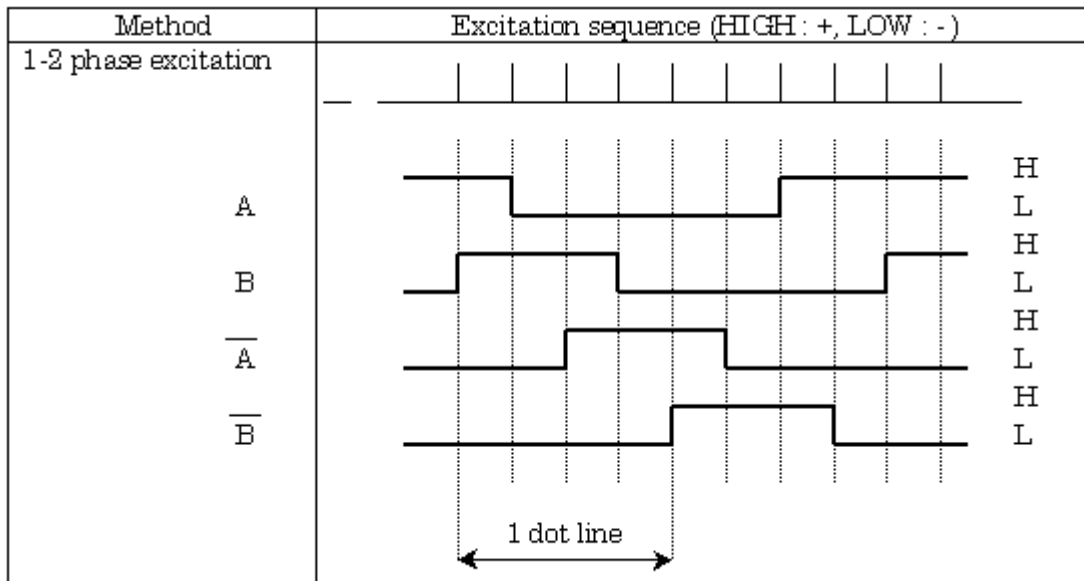

DATE    DOCUMENT CONTROL    SECTION  
 ↑

				TITLE FTP-632MCL353/354	
				PRODUCT SPECIFICATIONS	
				DRAW No. A1NA02242-0353/6	
				CUST	
EDIT	DATE	DESIGN	CHECK	DESCRIPTION	
DESIGN			CHECK	APPRY	FUJITSU TAKAMISAWA COMPONENT LIMITED
				DATE	19/19

(3) Motor control of FTP-6x2MCL series

1) Motor drive conditions

ITEM	CONTENTION
Drive method	Bipolar 1-2 phase drive
Drive current	480 mA
Drive voltage	24 V

2) Acceleration control method

(a) Control motor acceleration and deceleration as follows.

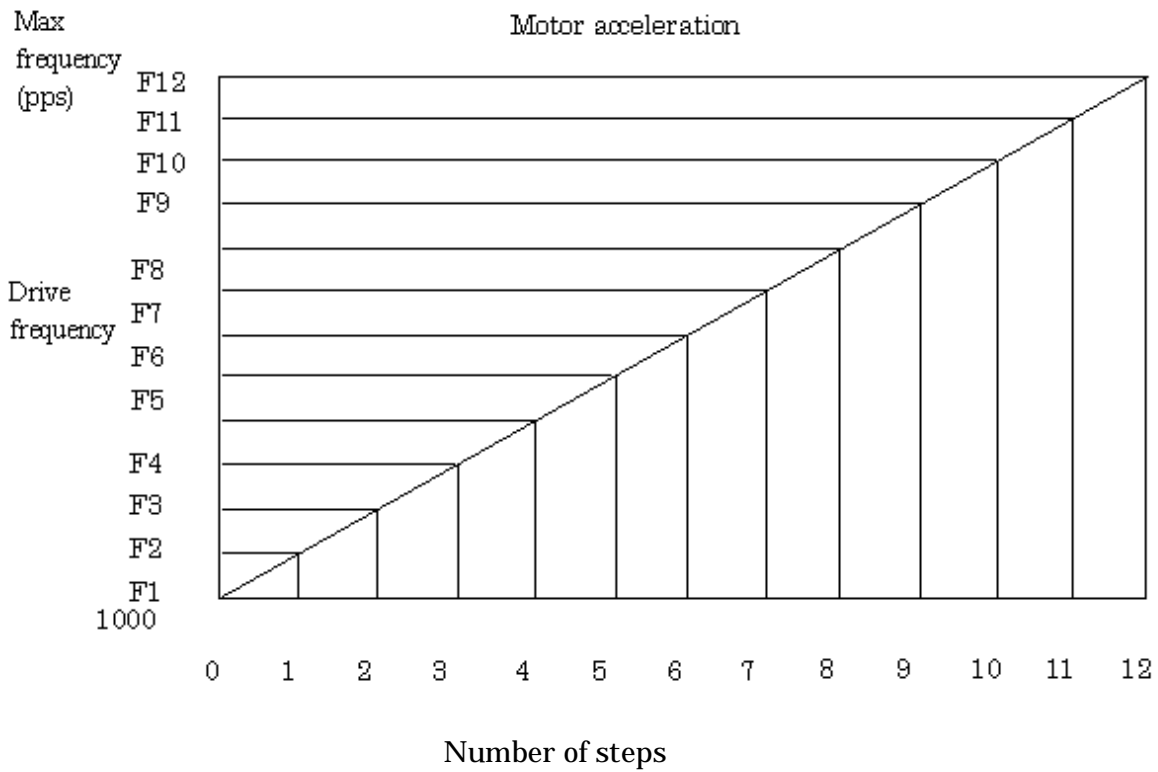

- (b) If motor excitation is off when acceleration is started, feed current though the motor for about eight ms beforehand.
- (c) After printing, wait in the 1-phase excitation state for about 10 seconds and hold the paper position until the start of the next printing.
- (d) After 10 or more seconds have passed from a printing end, turn off motor excitation to suppress heating.
- (e) If a trouble occurs, turn off the motor current.

DOCUMENT CONTROL SECTION

DATE

				TITLE FTP-632MCL353/354	
				PRODUCT SPECIFICATIONS	
				DRAW No. A1NA02242-0353/6	
				CUST	
EDIT	DATE	DESIGN	CHECK	DESCRIPTION	
DESIGN			CHECK	APPRY	
				FUJITSU TAKAMISAWA COMPONENT LIMITED	
				20/20	

(3) Motor drive condition

1) In this motor, coil resistance is suppressed low to prevent the current rise waveform from being dulled by the L component of the motor coil at high-speed drive. Drive this motor by a constant-current circuit (up to 500 mA) according to the drive circuit example to obtain stable torque over resistance value variation, voltage, etc.

Excessive current generates abnormal heat and excessive torque to damage the mechanical unit. Don't allow current that exceeds the required to flow.

2) Check the effect of temperature, humidity, paper type, etc. on load variation before determining the motor drive conditions. Motor drive with excessive torque may damage the gear at paper lock or other.

3) At low-speed drive (low drive frequency), abnormal noise or torque drop may occur because of motor resonance. Perform full evaluation and check to use a 500 pps or lower drive frequency.

4) Control acceleration and deceleration when rapidly changing the motor drive speed at printing start and when starting printing after motor excitation is turned off.

5) Perform dummy feed of several dot lines to match the motor excitation phase and remove the effect of the drive transmission system when starting printing after motor excitation is turned off.

(4) Notes

1) If the motor is stopped and motor excitation is discontinued during printing, the print may be separated because of the elasticity of the rubber roller when the motor is restarted. Print crush or white line insertion may occur. When print continuity is required, print all data at one time instead of stopping printing halfway. The above rubber roller deformation and other effect can also be reduced by feeding minute current in the standby state. In this case, the current as a guide is 150 mA

2) Turn off excitation to leave the printer unused for long time. The motor, drive element, or other may be heated.

3) Hold the motor side wall temperature 90°C or lower in use. Excess of 90°C may damage the coil in the motor.

4) When an abnormal condition occurs, stop printer drive as early as possible.

5) This printer feeds one dot line by four steps. Therefore, in motor drive by 1-2 phase excitation, control the motor so that stop occur in the 1-phase excitation state and start occurs in the 2-phase excitation state to save power and stabilize operation.

Printing operation with no paper and the head down may wear the rubber roller or damage the head. Don't perform printing in this condition.

DOCUMENT CONTROL SECTION

DATE

				TITLE FTP-632MCL353/354	
				PRODUCT SPECIFICATIONS	
				DRAW No. A1NA02242-0353/6	
				CUST	
EDIT	DATE	DESIGN	CHECK	DESCRIPTION	
DESIGN			CHECK	APPRY	
				FUJITSU TAKAMISAWA COMPONENT LIMITED	
				RII	21 / 21

(5) Example of stepping motor drive circuit

A

Figure 8 shows an example of the bipolar constant-current drive circuit.

B

C

D

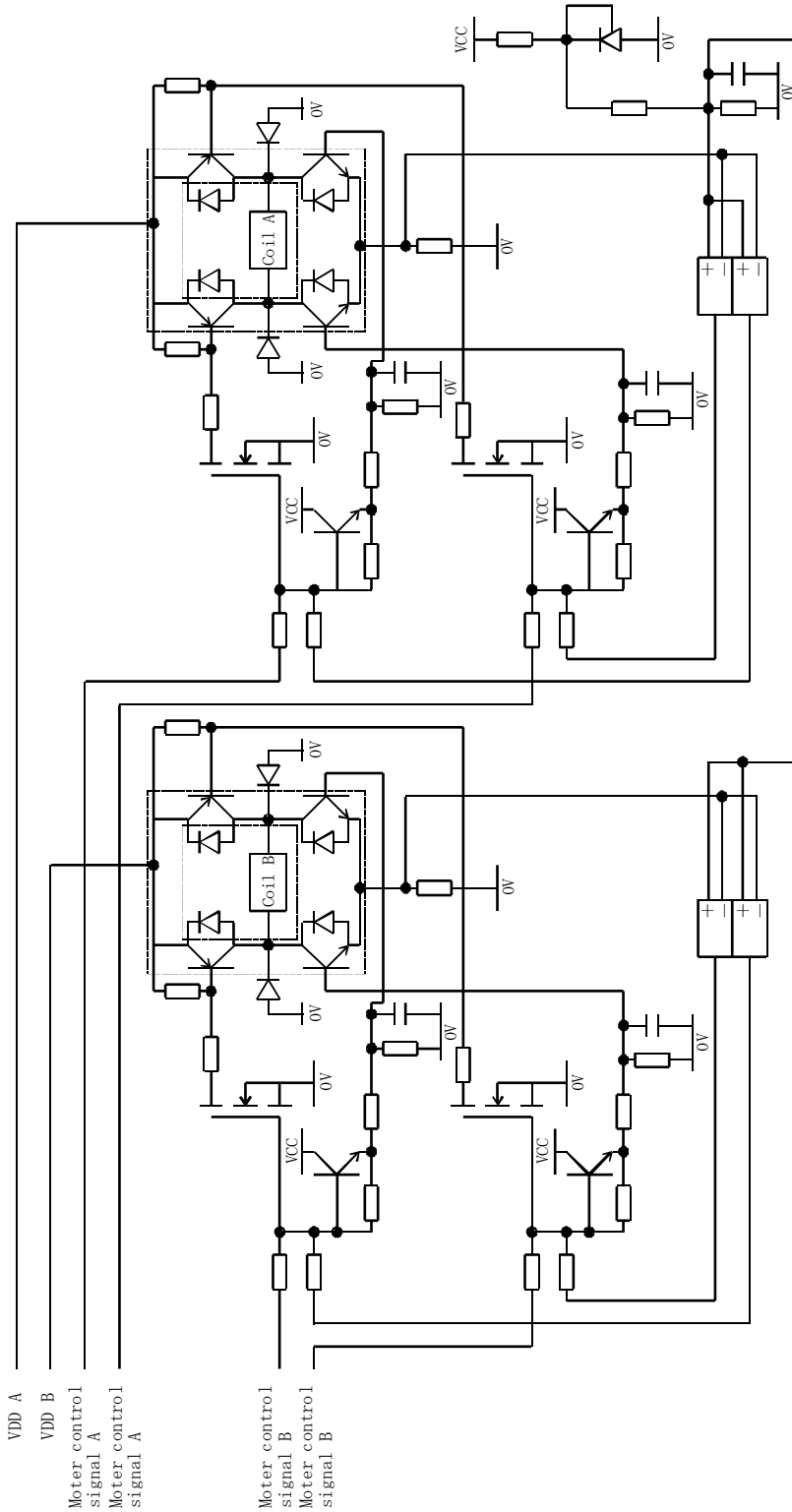

A

B

C

D

E

Figure 8

DATE	DOCUMENT CONTROL SECTION
------	--------------------------

				TITLE FTP-632MCL353/354	
				PRODUCT SPECIFICATIONS	
				DRAW No. A1NA02242-0353/6	
				CUST	
EDIT	DATE	DESIGN	CHECK	DESCRIPTION	
DESIGN			CHECK	APPRY	
				FUJITSU TAKAMISAWA COMPONENT LIMITED	
				22/22	

F

## 9. PHOTOINTERRUPTER SPECIFICATIONS

The main purpose of this photointerrupter is to position the paper by mark detection. This photointerrupter can also be used to detect no paper condition.

### (1) Absolute maximum ratings

Item		Symbol	Rated value	Unit
Input	Forward current	$I_F$	50	mA
	Reverse voltage	$V_R$	5	V
	Allowable loss	$P$	70	mW
output	Voltage between collector and emitter	$V_{CEO}$	20	V
	Voltage between emitter and collector	$V_{ECO}$	5	V
	Collector current	$I_C$	20	mA
	Collector loss	$P_C$	70	mW

### (2) Electrooptical characteristics

(25°C)

Item		Symbol	Minimum value	Typical value	Maximum value	Unit	condition
Input	Forward current	$V_F$	1.0	1.2	1.6	V	$I_F = 20 \text{ Ma}$
	Reverse voltage	$I_R$			10	$\mu\text{A}$	$V_R = 3 \text{ V}$
output	Dark current	$I_{CEO}$			200	nA	$V_{CE} = 10 \text{ V}$
Transmission characteristics	Photoelectric current	$I_C$	305		1100	$\mu\text{A}$	$V_{CE} = 5 \text{ V}$ $I_F = 10 \text{ mA}$
	Leakage current	$I_{LEAK}$			1	$\mu\text{A}$	$V_{CE} = 5 \text{ V}$ $I_F = 20 \text{ mA}$
	Response time (rise)	$t_r$		5		$\mu\text{s}$	$V_{CE} = 5 \text{ V}$ $I_F = 1 \text{ Ma}$
	Response time (fall)	$t_f$		5		$\mu\text{s}$	$R_L = 100\Omega$

DOCUMENT CONTROL SECTION

DATE

				TITLE FTP-632MCL353/354	
				PRODUCT SPECIFICATIONS	
				DRAW No. A1NA02242-0353/6	
				CUST	
EDIT	DATE	DESIGN	CHECK	DESCRIPTION	
DESIGN			CHECK	APPRY	
				FUJITSU TAKAMISAWA COMPONENT LIMITED	
				RILEE 23/23	

(3) Example of external connection circuit

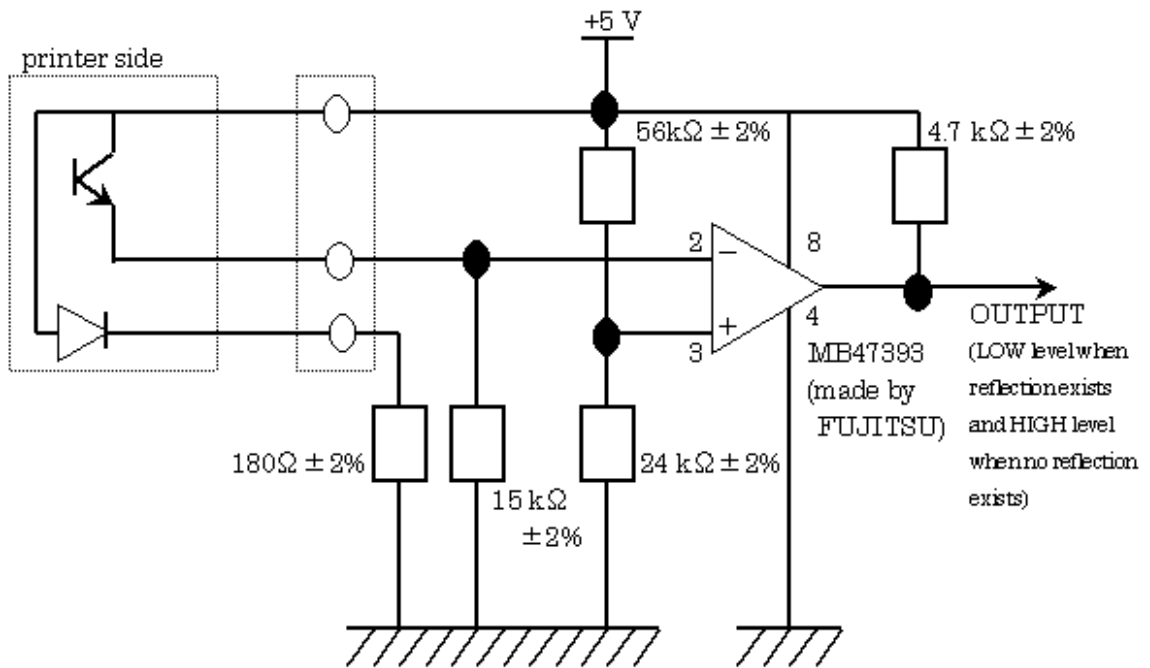

10. MICROSWITCH SPECIFICATIONS

Microswitches are built in to detect head up.

Item	Specifications
Rated voltage	DC 30V
Rated current	0.1 A
Minute load capacity	DC 5 V, 1 mA
Contact resistance	200 mΩ or less
Contact material	Gold

DATE	DOCUMENT CONTROL SECTION
------	--------------------------

				TITLE FTP-632MCL353/354 PRODUCT SPECIFICATIONS	
				DRAW No. A1NA02242-0353/6	
				CUST	
EDIT	DATE	DESIGN	CHECK	DESCRIPTION	
DESIGN			CHECK	APPRY	FUJITSU TAKAMISAWA COMPONENT LIMITED
				DATE	24/24

# 11.MARKING

## 11.1 Type and Serial Number Marking label

- (1) Contents :The type, manufacture serial number, and revision number are marked.
- (2) Application place : This label shall be applied on the side of the main body of the mechanical unit.
- (3) Marking method : The type number, serial number, and revision number shall be marked by stamping
- (4) Serial number marking : 6-digits serial number shall be marked in the following format :

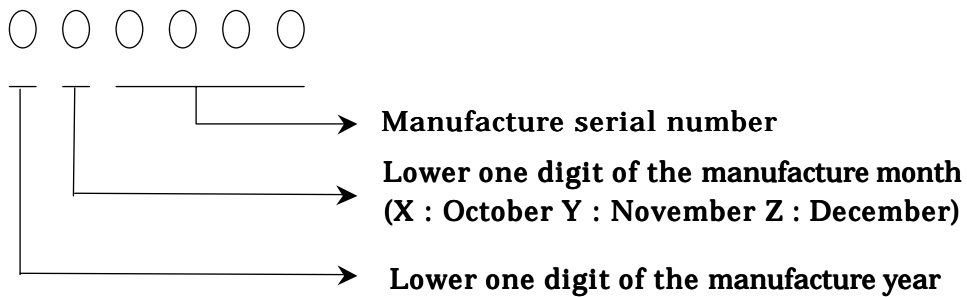

- (5) Revision number marking : Mark the revision of the printer.
- (6) Marking example : A marking example is shown below.

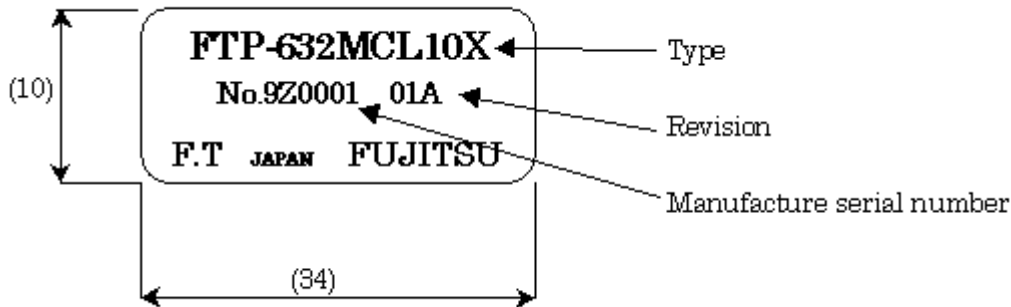

DATE	DOCUMENT CONTROL SECTION
------	--------------------------

					TITLE FTP-632MCL353/354	
					PRODUCT SPECIFICATIONS	
					DRAW No. A1NA02242-0353/6	
					CUST	
EDIT	DATE	DESIGN	CHECK	DESCRIPTION		
DESIGN			CHECK	APPRY	FUJITSU TAKAMISAWA COMPONENT LIMITED	25 / 25

**12.PACKING**

A  
B

- (1) Packing form  
Put each unit in an tistatic bag and pack it in the dedicated packing box.
- (2) Dimensions  
Comfort to the F&T standard.
- (3) Number of units piled  
Up to three units can be piled up in horizontal position.
- (4) Marking  
Mark the type and quantity on the surface of the packing box.

**13.Notes for handling**

(1) Notes for paper loading and unloading

Load the paper so that its shaft is as parallel with the printer as possible. (See the figure below)

Adjust paper ejection so that it's ejected smoothly without hitting the cover or other.

Without these treatments, trouble such as paper snaking, printing position misalignment, and paper jam may occur in printing.

C  
D

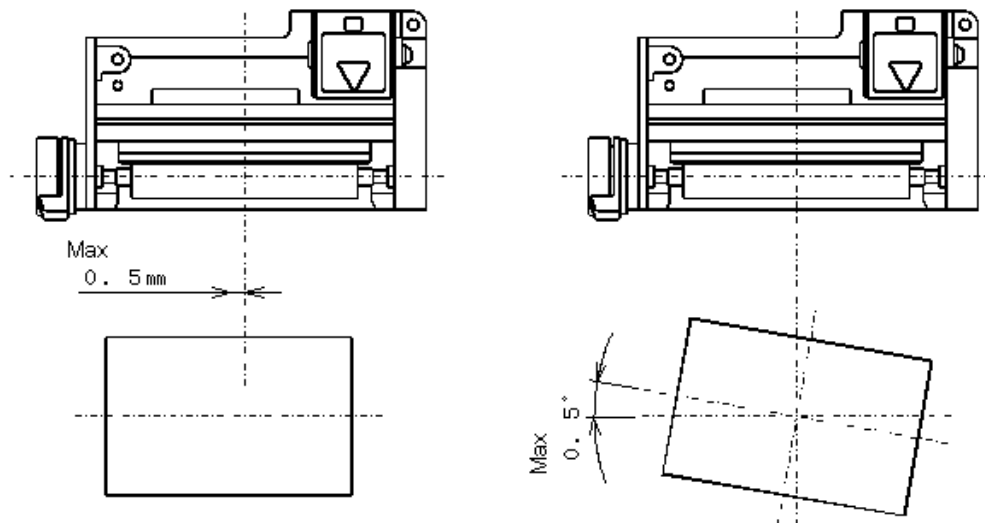

(2) Notes for storage

For long-time storage (half year or longer in room temperature), load paper and establish head up condition. Also load paper for short-time storage.

If the rubber roller remain in direct contact with the head and pinch roller for long time, the rubber roller may be partially deformed to cause uneven print darkness.

DOCUMENT CONTROL SECTION  
DATE

					TITLE FTP-632MCL353/354	
					PRODUCT SPECIFICATIONS	
					DRAW No. A1NA02242-0353/6	
					CUST	
EDIT	DATE	DESIGN	CHECK	DESCRIPTION		
DESIGN			CHECK	APPRY	FUJITSU TAKAMISAWA COMPONENT LIMITED	26 / 26

Don't place the printer in an environment in which condensation may occur with the power on for long time to prevent galvanic corrosion.

A

A

(3) Notes for mounting and setting

Secure the printer by 3 mounting holes using three M3.0 screw. At this time, support the printer by the same plate (flatness : 0.1 or less)

Connect the mounting section on the motor side to the frame ground of the main body.

A violation of these notes may cause trouble such as blurred printing, wavy paper, paper jam, and noise.

(4) Back tension of recording paper

B

B

When using this printer with the F&T standard circuit, adjust the back tension of the paper at the printer paper entrance to approx. 0.98N(approx. 100g.)

Application of back tension that exceeds 0.98N( 100g ) may cause a paper jam or overload and damage the gear.

(5) Galvanic corrosion

C

C

If head voltage is applied with the paper wet, the head may be damaged because of galvanic corrosion. Don't place the printer in an environment in which condensation may occur with the power on for long time.

(6) Dust and drip

The structure of this printer is neither dust-proof nor drip-proof. Give a treatment against dust and drips to the main-flame side beforehand.

(7) Other

D

D

Lift the head up lever when paper isn't loaded on the printer.

If the paper runs out during printing, stop printer operation to prevent printing with no paper.

This causes printer failures

E

F

DOCUMENT CONTROL SECTION	↑
DATE	

				TITLE FTP-632MCL353/354	
				PRODUCT SPECIFICATIONS	
				DRAW No. A1NA02242-0353/6	CUST
EDIT	DATE	DESIGN	CHECK	DESCRIPTION	FUJITSU TAKAMISAWA COMPONENT LIMITED
DESIGN			CHECK	APPRY	RII FILE
					27/27

14.OTHER

(1) Both side shall consult to solve occurred problems based on this specifications.

(2) Both side shall consult to make change and additions incompatible with this specifications. In the range of compatibility, this printer may be changed without prior notice because this type is a standard type.

(3) Preprinting

Consult on preprinting (printing on the paper) according to Appendix 1 beforehand. The ink used, printing method, and drying method of preprinting may affect the print quality of the thermal printer largely.

(4) Successive operation

Adjust the head board temperature to 70°C or lower by a theristor to protect the ICs in the printer from heat. Also adjust the surface temperature of the motor to 90°C or lower to protect the motor coil from heat.

(5) Label feed

Don't feed labels backward by turning the knob in reverse direction or other because it may cause the label to adhere to the inside of printer.

(6) Paper rolling direction

Roll the paper with the heat-sensitive side on the outside to make paper insertion easy and reduce the transport load at drive.

(7) Paper perforation

Perforate paper from the heat-sensitive side on the outside to make paper insertion easy and reduce the transport load at drive.

(8) Head cleaning

Paper residues or foreign matter may shorten the lift of the head or platen. Clean the printer periodically.

DATE	DOCUMENT CONTROL SECTION
------	--------------------------

					TITLE FTP-632MCL353/354	
					PRODUCT SPECIFICATIONS	
					DRAW No. A1NA02242-0353/6	
					CUST	
EDIT	DATE	DESIGN	CHECK	DESCRIPTION		
DESIGN			CHECK	APPRY	FUJITSU TAKAMISAWA COMPONENT LIMITED	
					RITTE	28/28

**Appendix 1**

Preprinting

1. Detecion mark position

Print the detection mark in a 5±1 mm x 10 mm or wider band on the heat-sensitive side as shown in the figure below.

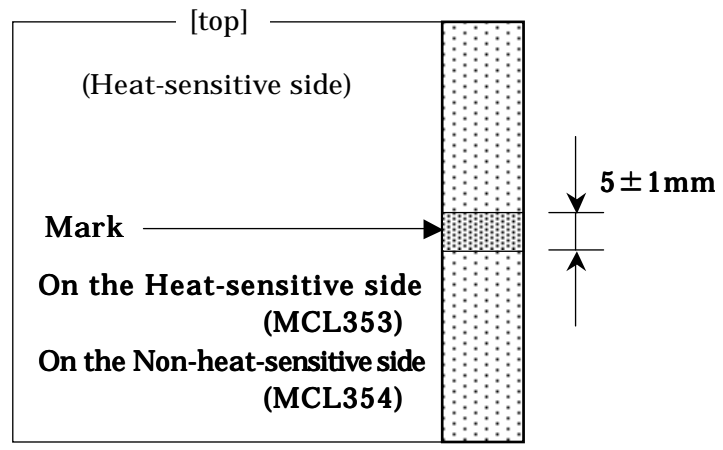

**Preprinting inhibited**  
 10 mm or more (MCL353)  
 15 mm or more (MCL354)

2. Pre-printing the positioning mark

The positioning mark should be printed as follows: the color is black, the reflection rate is equal or less than 7% and PCS is equal or more than 0.9 for the deepness.

To eliminate the light and shade, use the oil-base ink for printing the mark. To improve the PCS value, overprinting is recommended.

The measuring apparatus and value for deepness are described below.

- PCS measuring apparatus: GretagMacbeth reflection type densitometer PCM-II (Filter used: D-range of 900nm)

3. Prohibiting the pre-printing

Pre-printing in the range where the mark is detected (10 mm from the right edge) is prohibited; however, if pre-printing is required for absolute necessity, select the used ink so that the reflection rate is equal or more than 80% within the range where the wavelength band of the photo-interrupter is used (700-1000 nm).

DOCUMENT CONTROL SECTION

DATE

					TITLE FTP-632MCL353/354	
					PRODUCT SPECIFICATIONS	
					DRAW No. A1NA02242-0353/6	
					CUST	
EDIT	DATE	DESIGN	CHECK	DESCRIPTION		
DESIGN			CHECK	APPRY	FUJITSU TAKAMISAWA COMPONENT LIMITED	29/29

4. Cautions on pre-printing

The thermosensitive paper has different characteristics from those of general printed paper and non-carbon paper. In the print process, pay attention to the followings.

A Printing method

Print the thermosensitive paper by the UV print method because the drying characteristics of the ink is bad.

B Ink to be used

- (1) Select the ink that does not give unfavorable effects to the thermal printer, such as adhesion of work-up, wear of the head, and sticking.
- (2) The quantity of the ions, Na and K in the ink should be respectively equal to or less than 50ppm. In addition, the quantity of ion of Cl should be equal to or less than 100ppm.

Recommended ink: RNC type by F&K TOKA

- (3) The surface strength of the thermosensitive layer is weaker than that of the general printed paper; therefore, pay attention to tacks of the ink. Set the tack of the ink to about 6.0 for the general thermosensitive paper, to the same level as the non-carbon paper for the high saving type thermosensitive paper. However, when reducing the tack with a reducer, the quantity of addition should be equal to or less than 5%. (Failure to do so, the drying characteristics will be worse.)

- (4) Do not introduce too much quantity of the ink. Excessive amount of the ink may cause defectiveness of the printing color development and sticking of the thermal printer.
- (5) Materials used for the ink should be heat-resistant and have cooling effects. The same ink should be used for the non-thermosensitive paper side.
- (6) After the printing has been completed, confirm if the ink is contacted to the paper. Furthermore, the UV ink is generally weak to the water; therefore, care should be taken for controlling the dampening solution.
- (7) Make sure that transcription and blocking of the ink do not occur.
- (8) Do not remove the pre-printing with water or alcohol.

C Dampening solution

- (1) The thermosensitive paper is water-repellent; therefore, care should be taken for controlling the dampening solution.
- (2) Excessive amount of IPA of the dampening solution may cause color development fog; therefore, the amount should be equal to or less than 5% for the general thermosensitive paper, equal to or less than 10% for the high saving type thermosensitive paper, respectively.

D Others

- (1) When a large number of UV lamps are used, care should be taken for paper shrinkage due to heat (the flow direction, the width direction) and the color development fog.
- (2) The paper surface is quite smooth; therefore, set the rolling pressure to be strong.
- (3) When increasing in the PCS value of the positioning mark, perform the overprinting.
- (4) Sticking may occur in some pre-printing results; therefore, be sure to perform evaluation and confirmation with the actually operated unit.

DOCUMENT CONTROL SECTION

					TITLE FTP-632MCL353/354	
					PRODUCT SPECIFICATIONS	
					DRAW No. A1NA02242-0353/6	
					CUST	
EDIT	DATE	DESIGN	CHECK	DESCRIPTION		
DESIGN			CHECK	APPRY	FUJITSU TAKAMISAWA COMPONENT LIMITED	30/30