

NOTES :

1. MATERIAL :
 INSULATOR : HIGH TEMPERATURE THERMOPLASTIC , UL94V-0.
 COLOR : BLACK
 CONTACT : PHOSPHOR BRONZE.
2. APPLICATION : SD&HS SD&SDHC&MMC & MS&MS PRO&MagicGate MS&MS-ROM&MS I/O Expansion (It can protect the damage of MSDuo)
3. PLATING : CONTACT AREA :GOLD FLASH,10u" PLATED OVER Ni
 SOLDER AREA : Tin PLATED OVER Ni

107R-A D 0 0-R
 1 2 3

1.Type

A:SD/MMC/MS

2.Contact Plating

D:10u" Gold Plating

3.RoHS

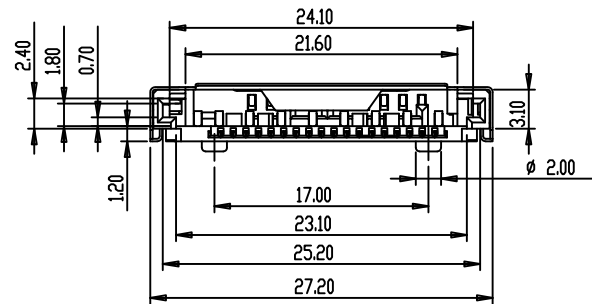
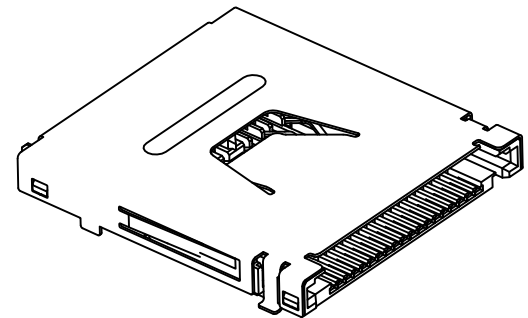

UNLESS OTHERWISE SPECIFIED TOLERANCE		
ANGLES	ANG.	±5°
LINEAR	0.	±0.3
	0.0	±0.25
	0.00	±0.20
SCALE	AS SHOWN	UNIT: mm
DRAWN	Willis	2012/08/03
CHECKED	Angel	2012/08/03
APPROVED	Ken	2012/08/03



www.attend.com.tw

DRAWN NAME:
Multi Card Socket
SD/MMC/MS

PRODUCT NO. 107R-AD00-R

FILE NAME 107R-AD00-R_B_1

REV.	DESCRIPTION	DATE	REV.	DESCRIPTION	DATE
1			2		
3			4		
5			6		
7			8		
9			10		

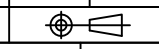

SIZE A4 REV. 1.0

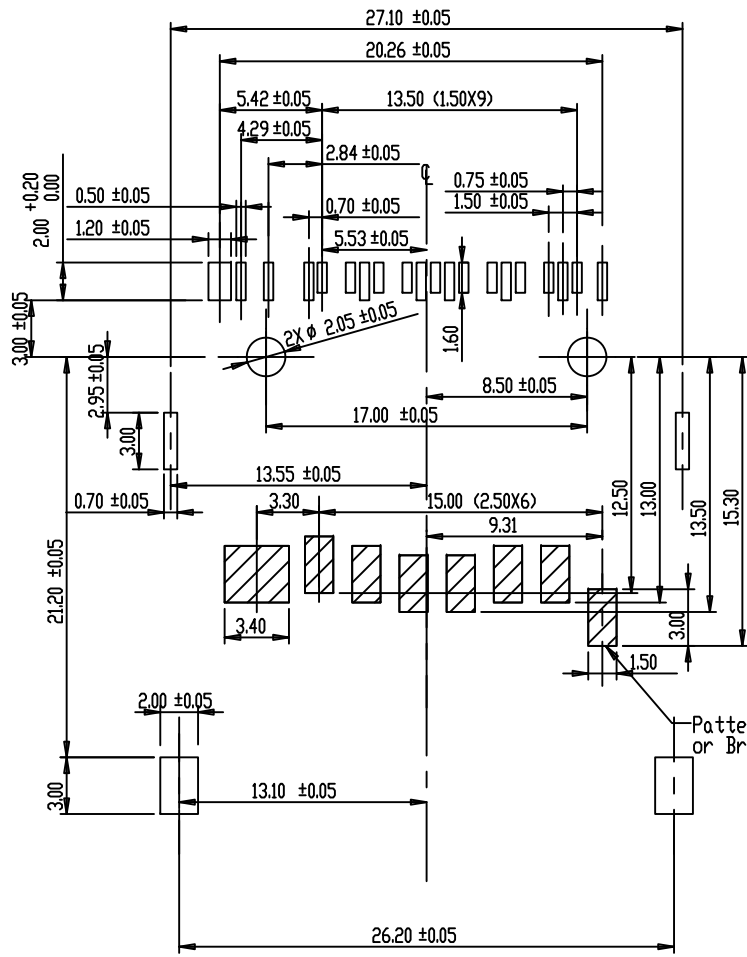

PCB LAYOUT

SD CIRCUIT :

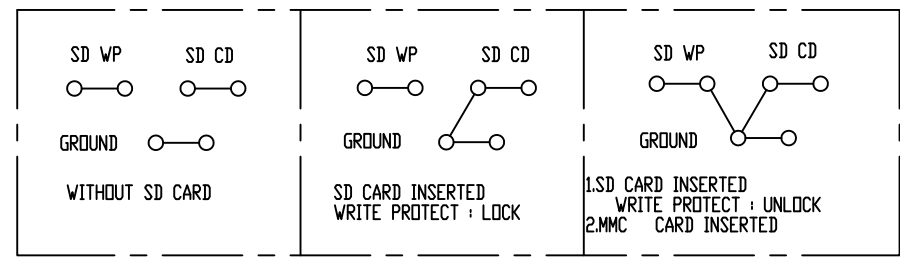

				UNLESS OTHERWISE SPECIFIED TOLERANCE			 www.attend.com.tw	
ANGLES		ANG.		±5°				
LINEAR		0.		±0.3				
		0.0		±0.25				
		0.00		±0.20				
SCALE		AS SHOWN		UNIT: mm				
△	Revise:			DRAWN	Willis	2012/08/03	DRAWN NAME:	
△	Revise:			CHECKED	Angel	2012/08/03	Multi Card Socket SD/MMC/MS	
△	Revise:			APPROVED	Ken	2012/08/03	PRODUCT NO.	107R-AD00-R
REV.	DESCRIPTION	DATE	REV.	DESCRIPTION	DATE	SIZE	REV.	FILE NAME
1						A4	1.0	107R-AD00-R_B_1

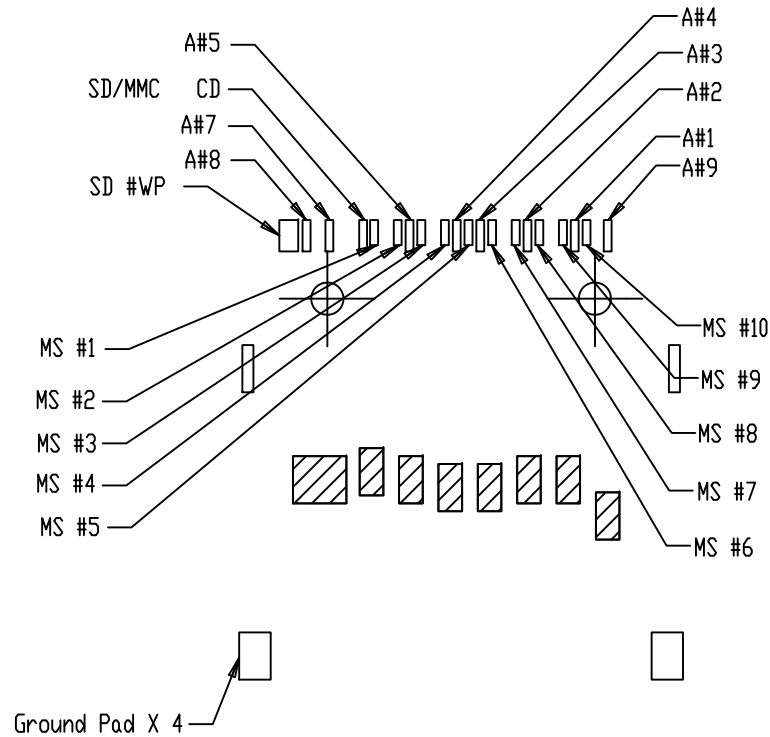

PCB LAYOUT

PIN ASSIGNMENT:

PIN NO.	MEMORY CARD PIN NO.
A#1	SD/MMC-1 (DAT3)
A#2	SD/MMC-2 (CMD)
A#3	SD/MMC-3 (GND)
A#4	SD/MMC-4 (VCC)
A#5	SD/MMC-5 (CLK)
A#7	SD/MMC-7 (DAT0)
A#8	SD-8 (DAT1)
A#9	SD-9 (DAT2)
MS#1	VSS
MS#2	BS
MS#3	DAT1
MS#4	SDIO/DATA0
MS#5	DATA2
MS#6	INS
MS#7	DATA3
MS#8	SCLK
MS#9	VCC
MS#10	VSS

(SD/MMC : SD&HS SD&SDHC&MMC CARD)

(MS : MS&MS PRO&MagicGate MS&MS-ROM&MS I/O Expansion CARD)

UNLESS OTHERWISE SPECIFIED TOLERANCE		
ANGLES	ANG.	±5°
LINEAR	0.	±0.3
	0.0	±0.25
	0.00	±0.20
SCALE	AS SHOWN	UNIT: mm
DRAWN	Willis	2012/08/03
CHECKED	Angel	2012/08/03
APPROVED	Ken	2012/08/03



www.attend.com.tw

DRAWN NAME:	
Multi Card Socket SD/MMC/MS	
PRODUCT NO.	107R-AD00-R
FILE NAME	107R-AD00-R_B_1

REV.	DESCRIPTION	DATE	REV.	DESCRIPTION	DATE
1			4		
2			5		
3			6		

Revise:
Revise:
Revise:

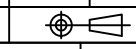

SIZE A4 REV. 1.0